

LEGACY ENDURA

Technical Specifications & Assembly

Internal Drawer Kit, 88mm Height



Product Features

- Modern Straight Slim box drawer system
- Silent system guarantees quiet, smooth run
- Dynamic load capacity: 40kg (88lbs)
- Concealed slide with full extension
- Tool free assembly and removal of drawer
- 2 Directional Adjustment

Standard Drawer Kit (packaged as a complete set)

- One pair of Full Extension Soft-Close Slides
- One pair of Endura Drawer Sides
- One set of inner cover caps
- One set of support brackets for bottom panel

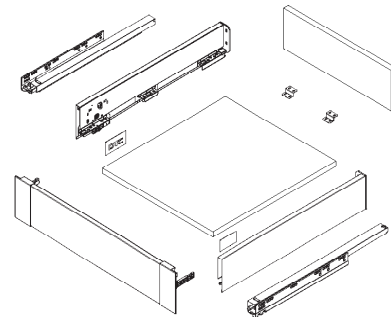

Internal Drawer Kit Ordering Guide

Length (mm)	Length (Inch)	Matte Grey	Silk White
270mm	11"	105-MS88-GM270	105-MS88-SW270
300mm	12"	105-MS88-GM300	105-MS88-SW300
350mm	14"	105-MS88-GM350	105-MS88-SW350
400mm	16"	105-MS88-GM400	105-MS88-SW400
450mm	18"	105-MS88-GM450	105-MS88-SW450
500mm	20"	105-MS88-GM500	105-MS88-SW500
550mm	22"	105-MS88-GM550	105-MS88-SW550

Additional Parts (Required)

Description	Part#
Front Fixing Plastic Bracket 88mm Height "Grey" for Inner Drawer	105-HE11012-GM
Front Fixing Plastic Bracket 88mm Height "White" for Inner Drawer	105-HE11012-SW
Internal Metal Drawer Front Panel 1100mm "Matte Grey"	105-HT10022-GM
Internal Metal Drawer Front Panel 1100mm "Silk White"	105-HT10022-GM

Installation Dimensions Inner Drawer

Soft close slides: $LT=NL+3$

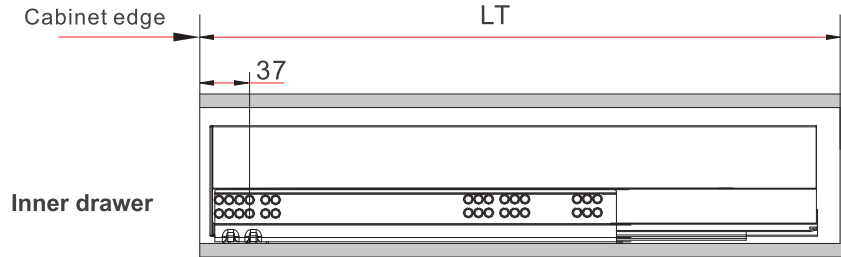

Space Requirements

Front Installation

Drilling Pattern

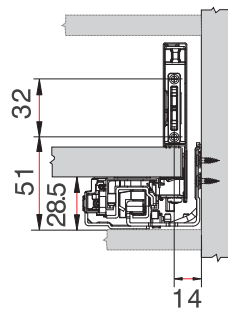
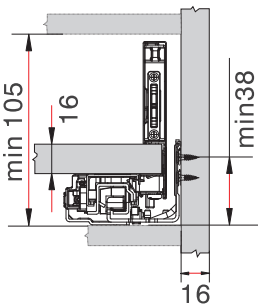

Cut to Length 1100mm Metal Drawer Front

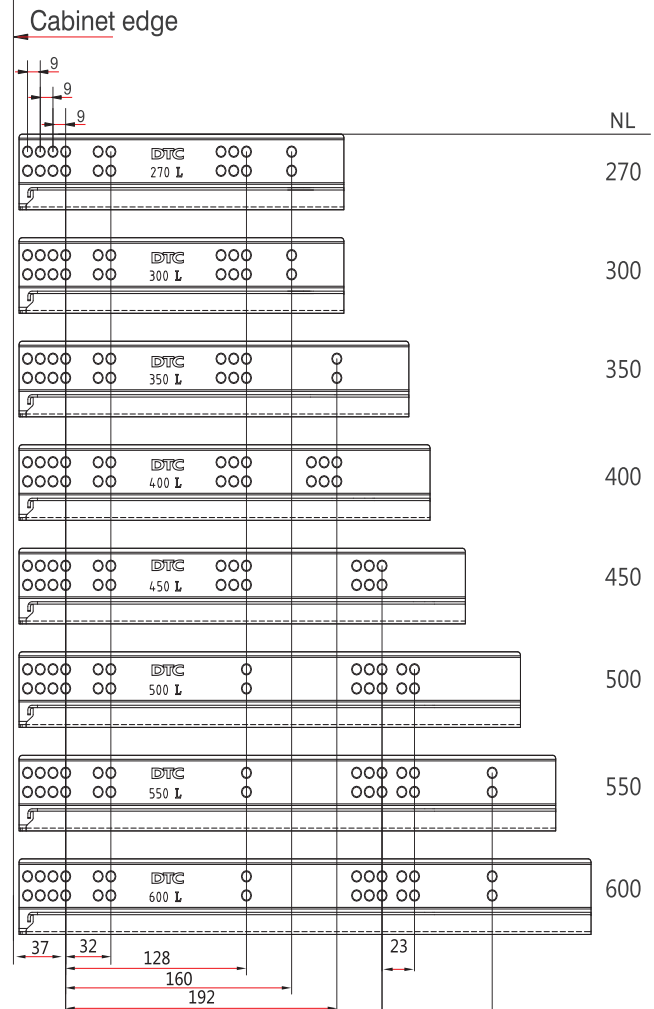
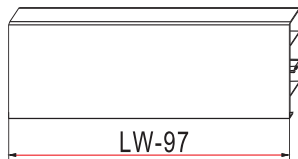

Back Installation

Drawer Front Drilling

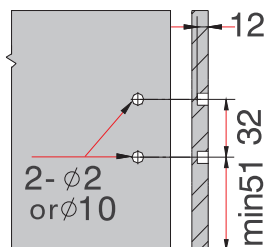
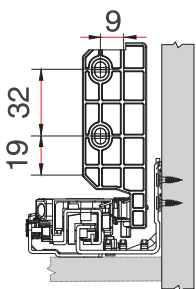

Back & Bottom Dimensions

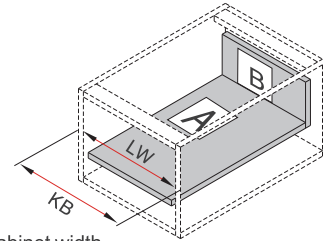
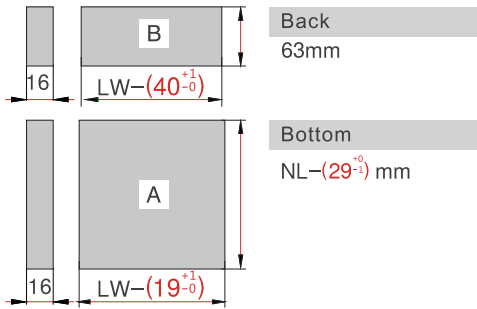

- KB Cabinet width
- LW Internal cabinet width
- NL Nominal length

Bottom & Back Assembly

Front Bracket Assembly

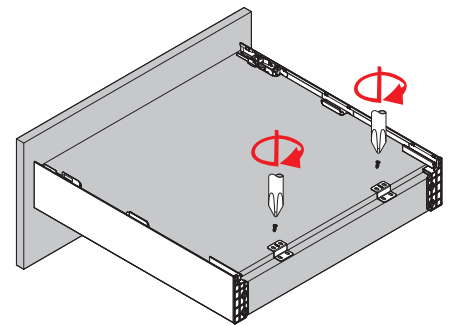
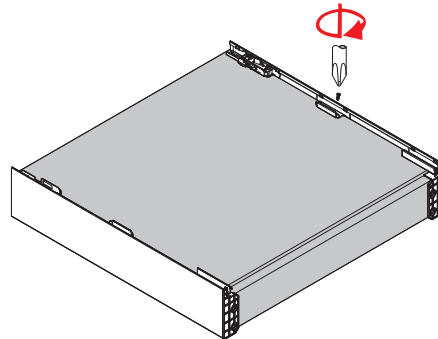
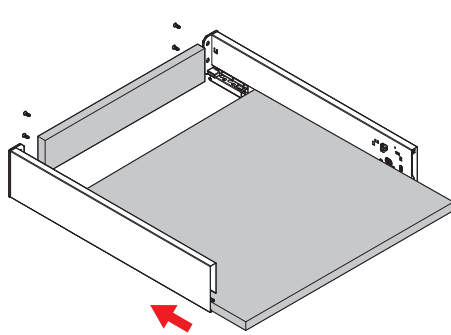

Drawer Front Assembly

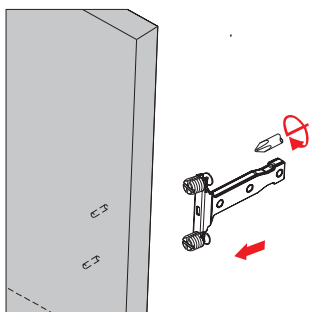

Fixing-Brackets Assembly

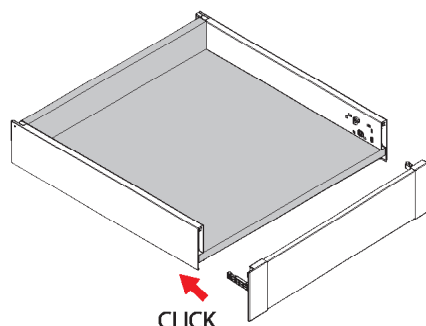

Drawer Front Assembly

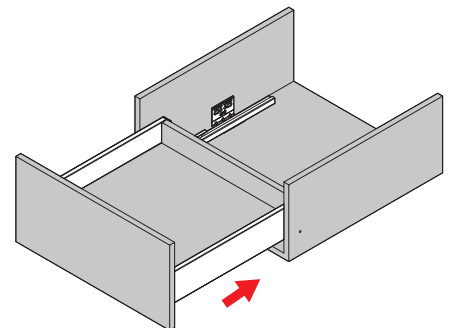

Slide Into the cabinet

Adjustment

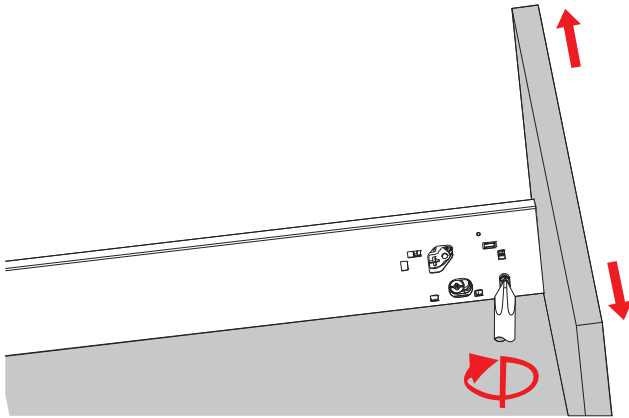

Left & Right Adjustment

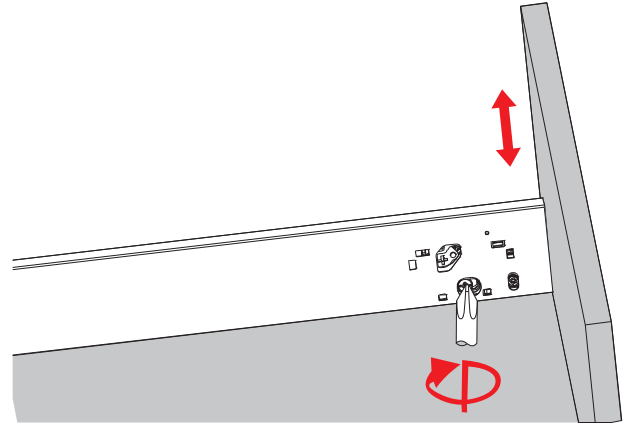

Up & Down Adjustment

Removal

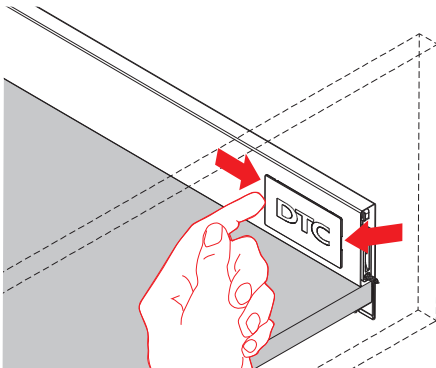

Remove the cover cap

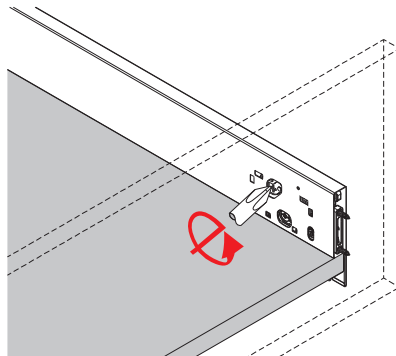

Turn screw driver to release the drawer front

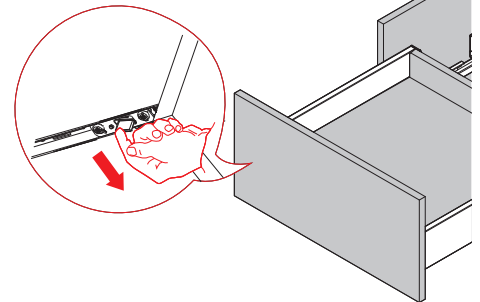

Press the locking device under the drawer box and pull out the drawer

Internal Drawer Front Assembly

