

TECHNICAL INFORMATION

Wood panelling with recessed profiles

When machining the wood panelling, leave 100 mm from the top and from the bottom of the panel.

Dimensions for machining the wood panelling.

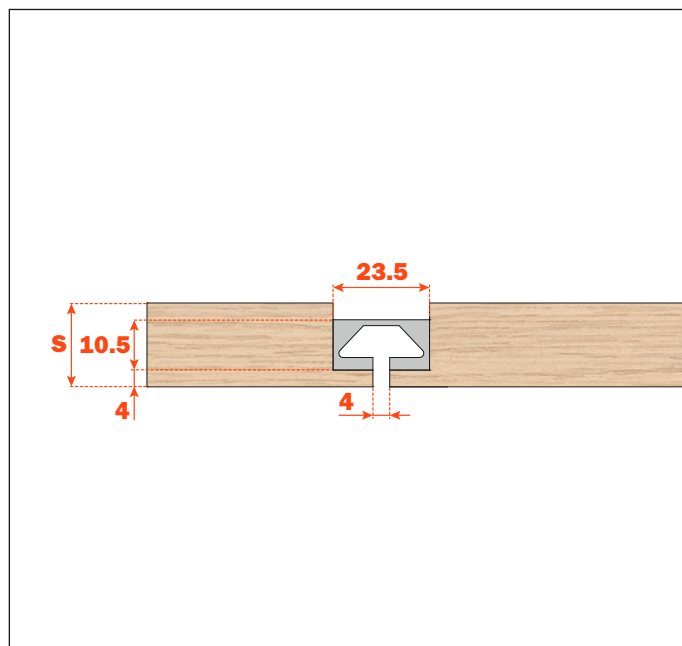
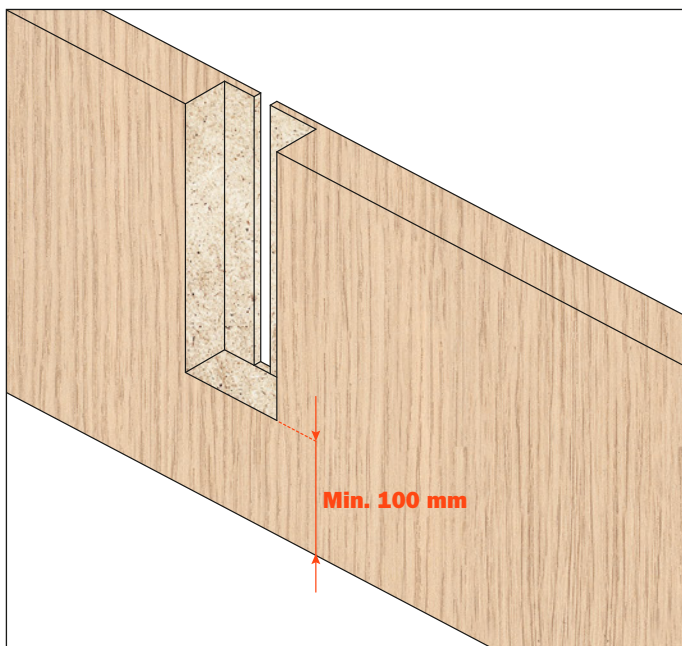

Surface-mounted profiles

Drilling the wood panel to fix the surface-mounted profile.

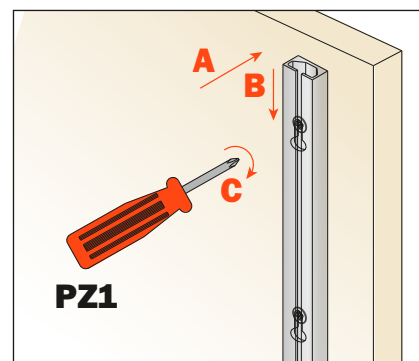
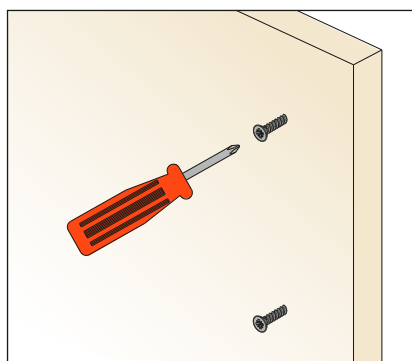
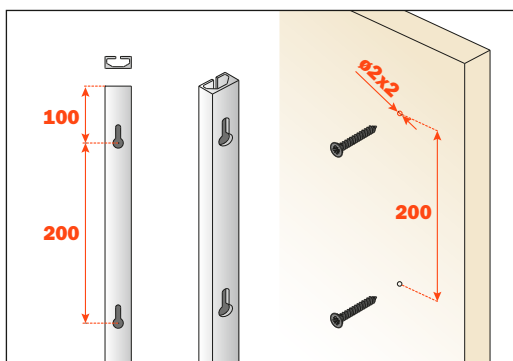

Drilling the wall to fix the surface-mounted profile.

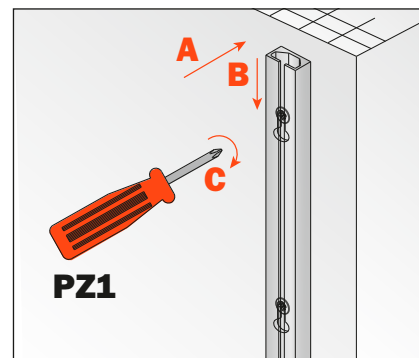
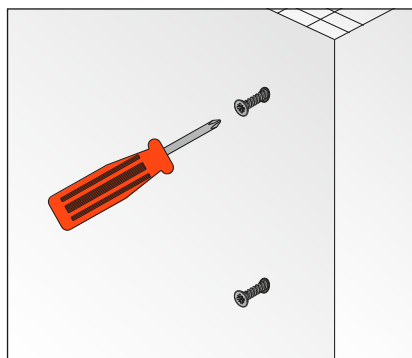
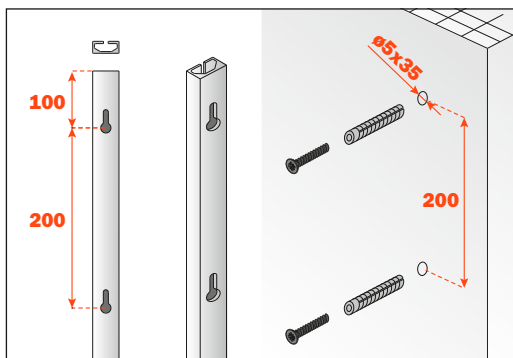

SCREWS PACKING

V073X205MP: screws for profile with aluminium finish (240 screws for wood panel, 240 screws with wall plugs)

V073X206MP: screws for profile with titanium finish (240 screws for wood panel, 240 screws with wall plugs)