

Dunbar Pull 320mm Matte Brushed Black/Silver



Part Number: 9370-320-MBBS

Dunbar Contemporary Pull, 320mm, Matte Brushed Black/Silver

The Dunbar's sleek, curved design fits virtually any furniture or cabinetry application.

Center to Center Length	320 mm
Collection	Dunbar
Colour Group	Dark Grey
Finish Code	Matte Brushed Black Silver
Material	Aluminum Diecast
Overall Length	361 mm
Projection (Height)	36 mm
Style Family	Contemporary

Product Description

The *Contemporary* lineup is a wide selection of modern designs that embody sleek, flowing lines and on-trend finishes. These diverse knobs and pulls can bring life to your space by adding a modern touch to your design or complementing an overall fashionable theme.

Our complete Decorative Hardware lineup is globally sourced, using some of the best materials available in the industry. We strive to offer in the latest on-trend finishes and exclusive, awe-inspiring European designs, in our high-quality decorative hardware. And it's all backed by our Limited Lifetime Warranty.

Included Products

Industry standard mounting hardware



Technical Documents

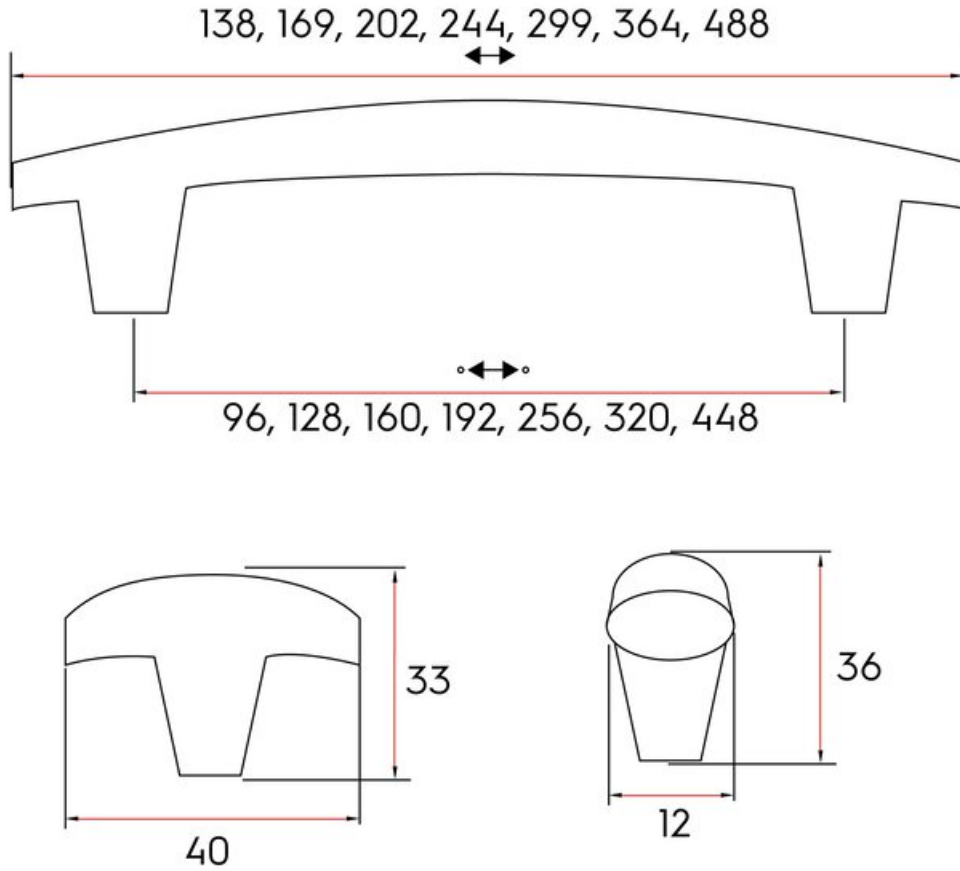

View this product online at <https://marathonhardware.com/pd/9370-320-MBBS>

