

Locking Shelf Support for 5/8" Shelf Board - Clear

Part Number: 03-2427



A clear (transparent) plastic shelf support with a built-in locking clip for 5/8" shelf boards.

Colour	Clear
Material	Plastic
Pin Diameter	5 mm

Product Description

The plastic shelf support with built-in locking clip is a quick and easy way to add shelving to cabinet interior. The locking clip holds the shelf in place, reducing the chances of spills or items falling.

Product Advantages

- Designed for 5/8" shelf boards
- Built-in locking clip
- Clear (transparent) to blend in with all cabinet interior colours



Technical Documents

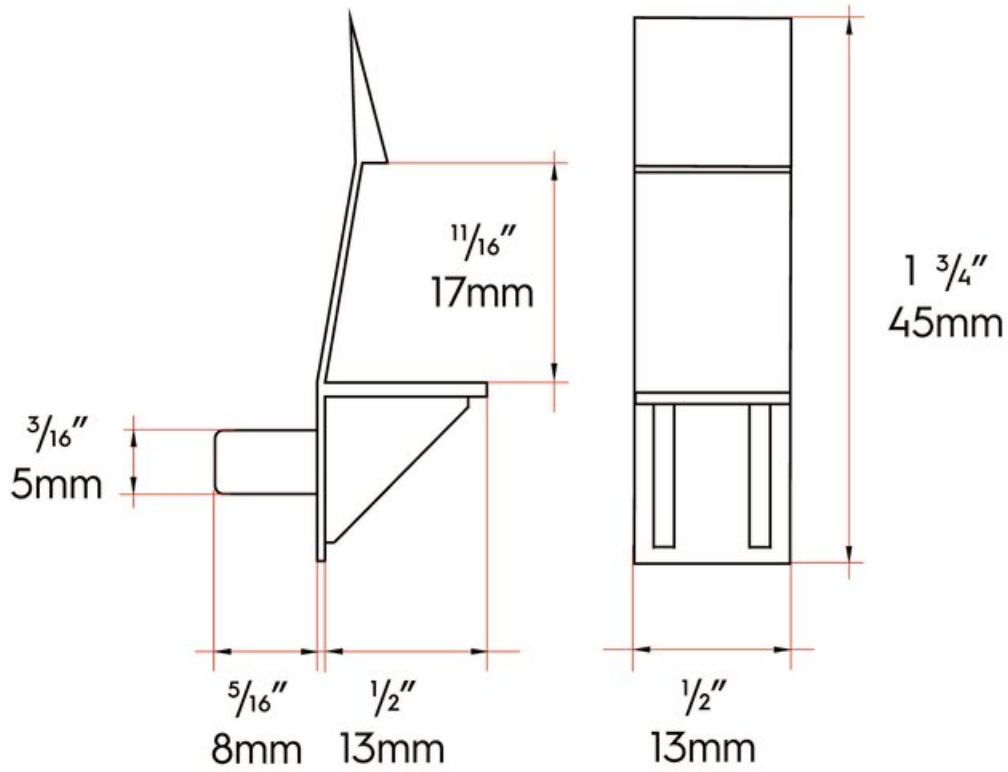

View this product online at <https://marathonhardware.com/pd/03-2427>



Technical Documents

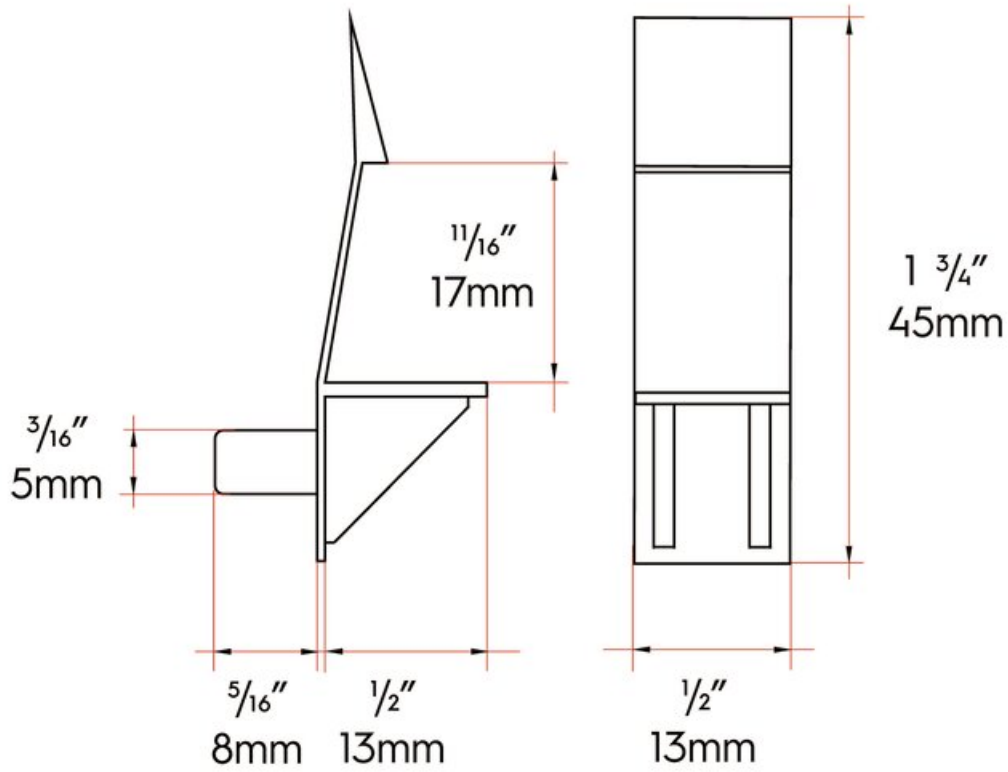

View this product online at <https://marathonhardware.com/pd/03-2427>

