



Leveler Head w/Expansion Dowel Black

Part Number: 03-3295

Height ----- From 4-1/4 to 6in



Technical Documents

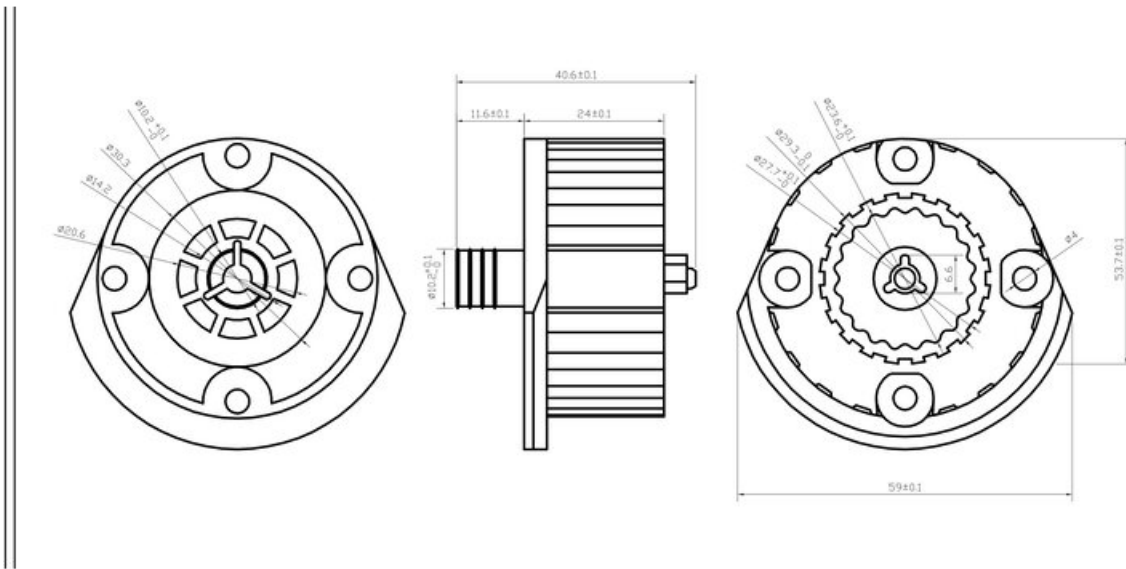

View this product online at <https://marathonhardware.com/pd/03-3295>

