

## Float Mounting Clips (set of 2) Matte Black

**Part Number: 086-F1FXE-MB**



Float Mounting Clips (Set of 2pcs) Matte Black

Use these mounting clips to securely fix to a back wall. Adjustable via slot.

Finish -----	Matte Black
--------------	-------------

### Product Description

Eureka FLOAT is a chic, wall mounted modular shelving system that is extremely versatile and customizable. FLOAT can be arranged in virtually any configuration you can imagine via the multitude of available connectors. FLOAT shelving system can be cut-to-size and assembled into countless designs to either “float” on the wall, or integrate into new or existing cabinetry.

### Product Advantages

### Important Information

A pair of mounting clips will support 30 kgs but this depends on a secure connection with your wall. We recommend adjusting the placement of your mounting clips into a stud wall wherever possible, or using adequate load-rated drywall mounting plugs.

When combining float into larger structures using the 4-way and 5-way connectors, consider adding additional mounting clips at the bottom and middle portions to better support and share the load. Additional mounting clips will increase the total weight carrying capacity of the entire shelf by approximately 30kg. See technical specifications for some more examples of estimating load capacity.

### Product Application

#### Shelf Dimensions

Wood Shelf:

- Length minus 42mm
- Depth minus 42mm

Glass Shelf:

- Length minus 42mm
- Depth minus 45mm

-----



## VERTICAL AND FRONT ADJUSTMENTS

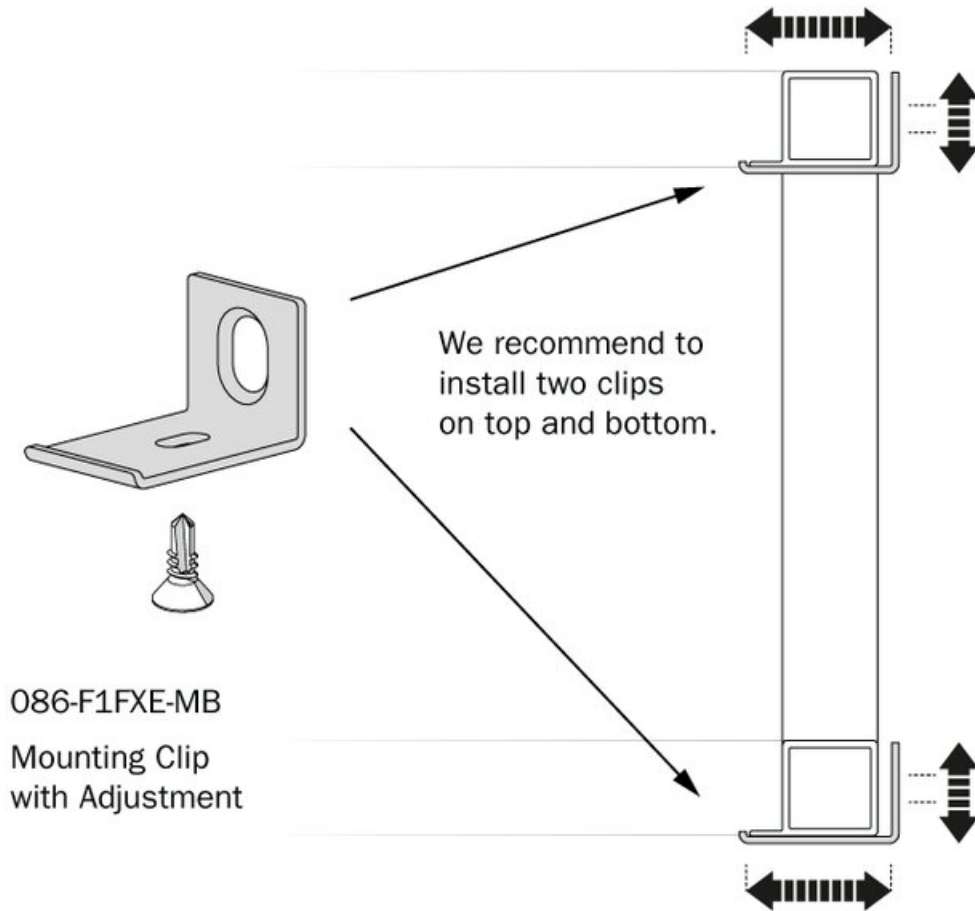

View this product online at <https://marathonhardware.com/pd/086-F1FXE-MB>



## Technical Documents

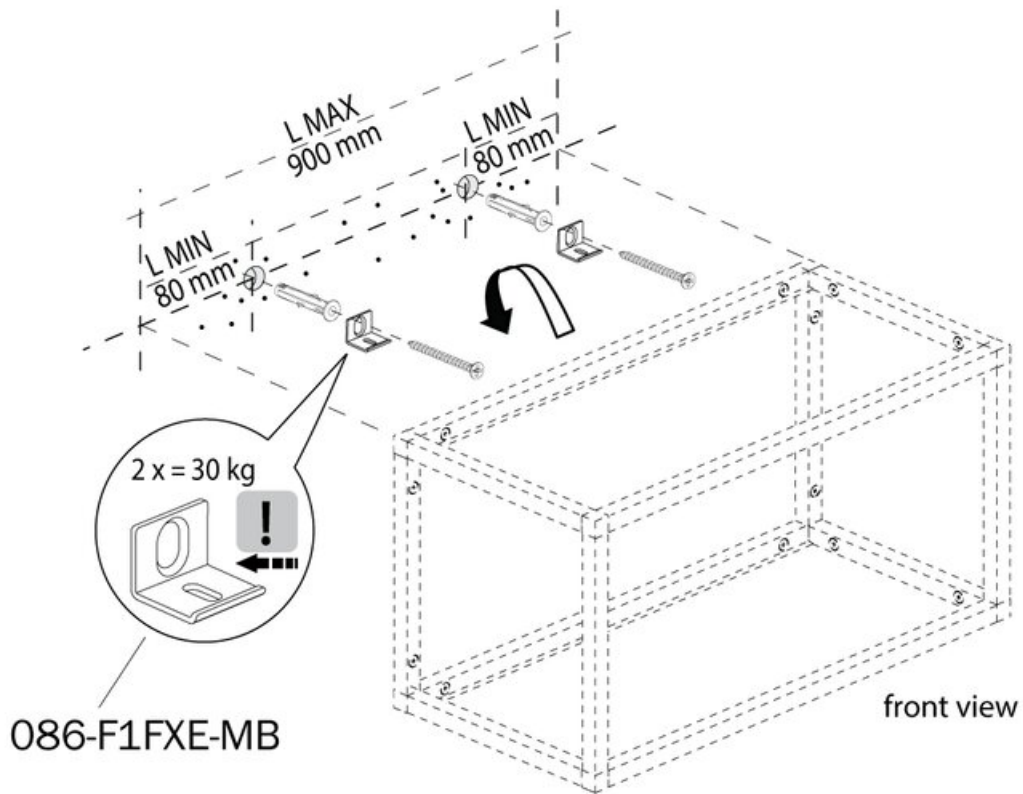

View this product online at <https://marathonhardware.com/pd/086-F1FXE-MB>

## Technical Documents

### Technical Specifications

Eureka FLOAT Accessories	
Item Description	Part#
Wall Mounting Clips (Set of 2), Matte Black	086-F1FXE-MB
Drilling Template Jig	086-PIPRI
Extra Screws for Connectors, Matte Black	DFE-AMXXI-MB
Allen Key/Hex T-Handle Tool, 3mm	MAR-THEX-3MM

- Maximum recommended shelf width is 900mm (36in)
- Max load for each section hanging off a pair of mounting clips is 30kg
- Increase load by installing additional clips in lower sections

### Mounting to the Wall

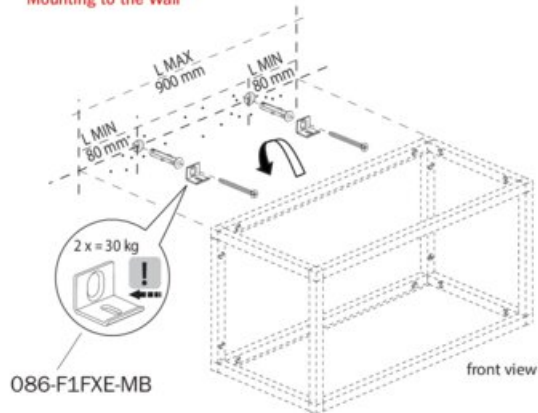

### Calculating Load Capacity

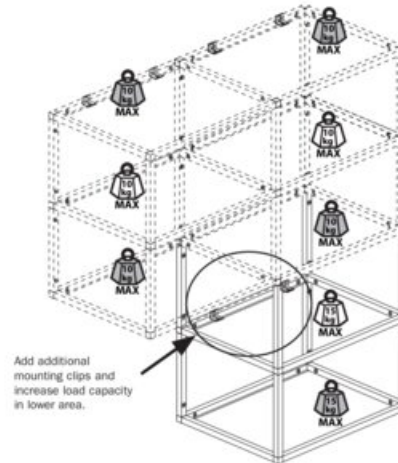

View this product online at <https://marathonhardware.com/pd/086-F1FXE-MB>

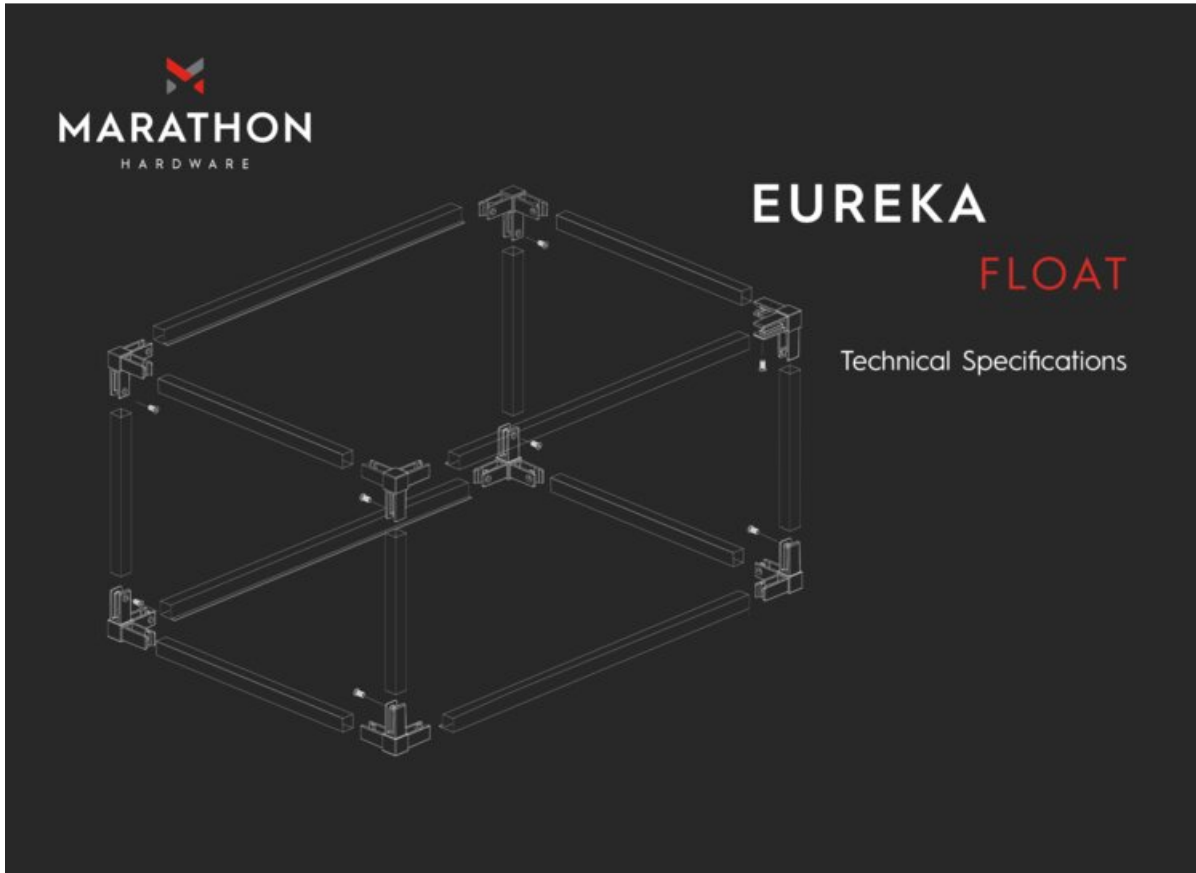

View this product online at <https://marathonhardware.com/pd/086-F1FXE-MB>



## Technical Documents



# FLOAT



### INSTRUCTIONS

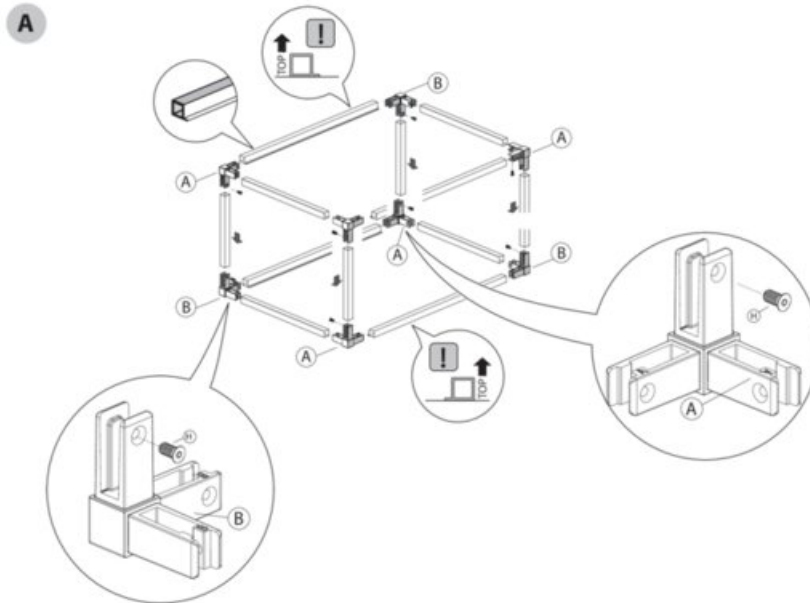

View this product online at <https://marathonhardware.com/pd/086-F1FXE-MB>

