Door Hinge for Concertina System

Part Number: SF1C169



Salice Door Hinge for Concertina System

Salice's Concertina Doors System has been designed to open both doors on one side only, giving good access to the interior of the cabinet.

<p>
</p>

Product Advantages

Space taken up by the door in the maximum open position is reduced to a minimum (approximately 80 mm).



Technical Documents

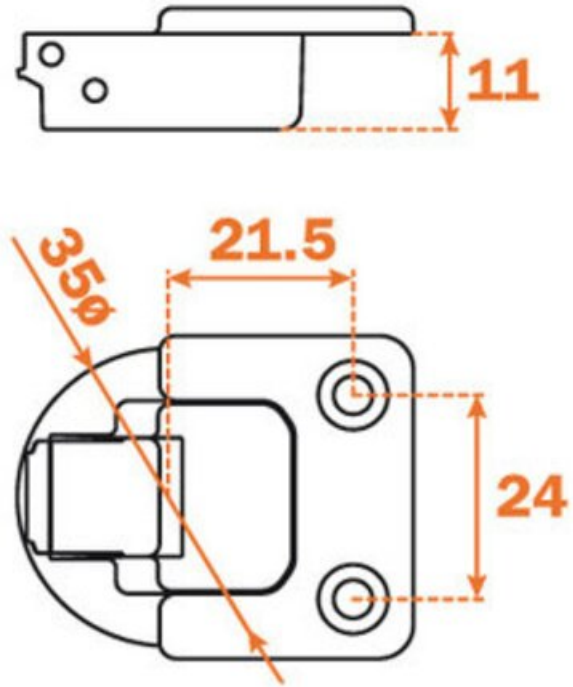

View this product online at <https://marathonhardware.com/pd/SF1C169>



Technical Documents



View this product online at <https://marathonhardware.com/pd/SF1C169>

