

## Stabilizer for 500mm Double Wall Drawer

**Part Number: 105-M01081-500**



These stabilizers help with the smooth and silent closing action and to prevent racking. Recommended when your Doublewall Drawer is wider than 900mm up to 1200mm.

Drawer System -----	Infinity Doublewall
Finish -----	Grey
Length -----	500mm (20in)



## Technical Documents

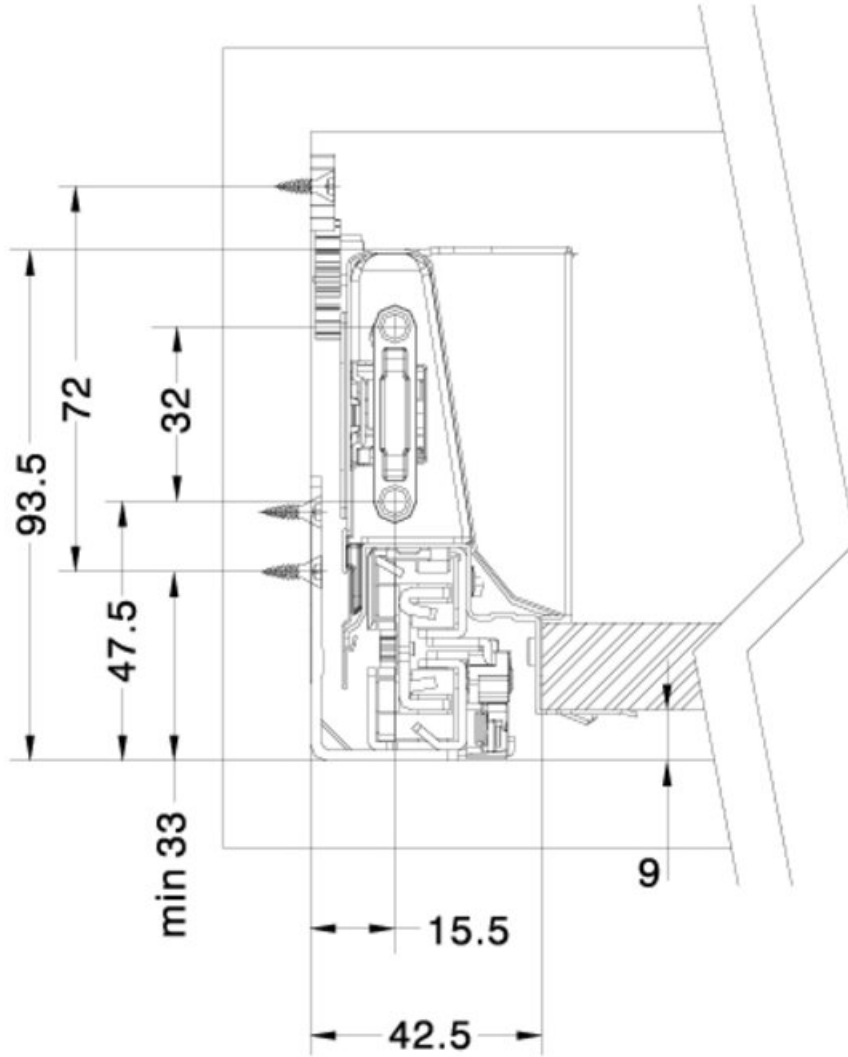

View this product online at <https://marathonhardware.com/pd/105-M01081-500>



## Technical Documents

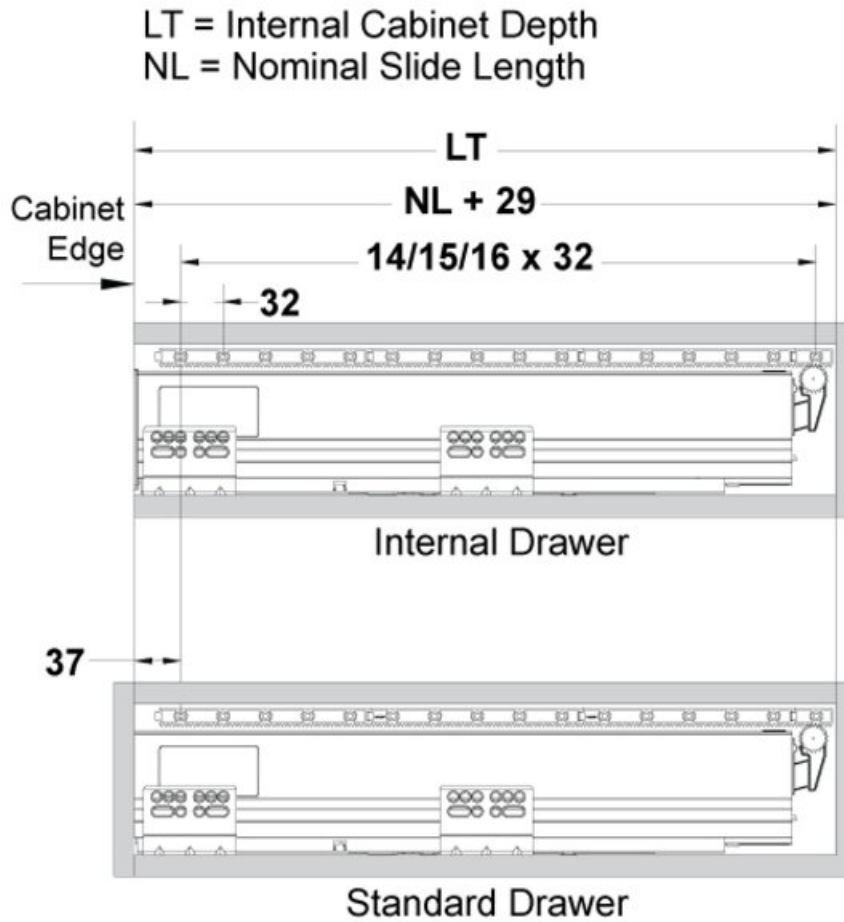

View this product online at <https://marathonhardware.com/pd/105-M01081-500>



## Technical Documents

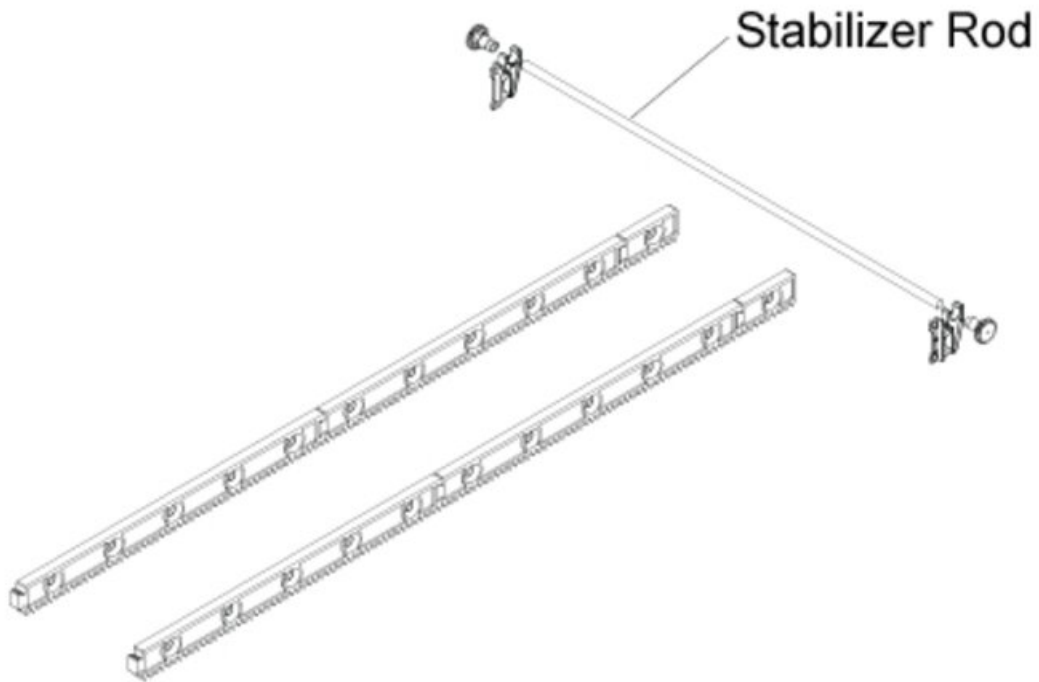

Stabilizer Rod Length =  
Internal Cabinet Width - 9mm

Please cut to length from 1200mm.

View this product online at <https://marathonhardware.com/pd/105-M01081-500>



## Technical Documents



## Internal Stabilizer for Wide Doublewall Drawers

### Product Features

- Provides extra strength and rigidity for wider drawers.
- Required for drawers from 900 to 1200mm wide.
- Helps to prevent racking by coordinating the movement of the independently installed slides.
- Maintains the smooth and silent Soft-Close for the lifetime of the slide.



Item No.	Length
105 M01081 450	450mm
105 M01081 500	500mm
105 M01081 550	550mm

### Interior Cabinet Space Requirements

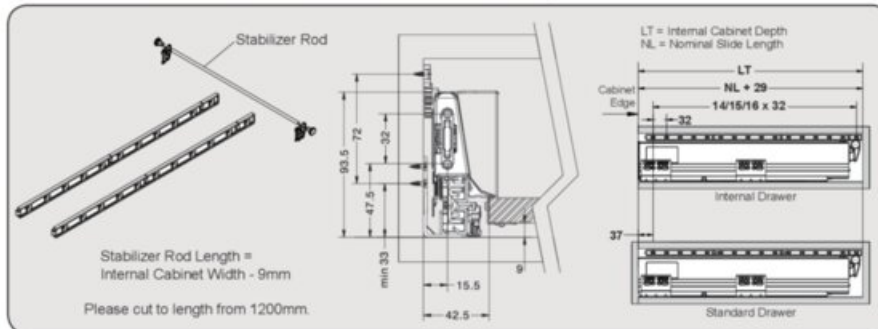

### Installation Procedure

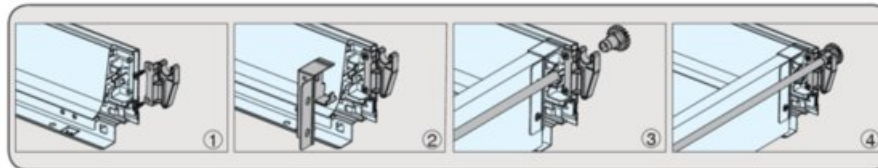

West (1 800 840 1228)

East (1 800 465 8665)

[www.marathonhardware.com](http://www.marathonhardware.com)

View this product online at <https://marathonhardware.com/pd/105-M01081-500>

