

M51 Synchronization Rod for Push 1100mm

Part Number: 105-M51-M0FH02

This rod is recommended for Push Opening drawer systems wider than 400mm.

<div>
</div>

Closing Type	-----	Infinity Push System
Drawer System	-----	Infinity Doublewall
Length	-----	1100mm (43-1/4in)

Product Advantages

- Synchronizes slides for perfect open
- Long rod can be cut to size
- Easy to install

Important Information

Cutting Dimension for the Rod is Internal Cabinet Width minus 114mm (LW-114)

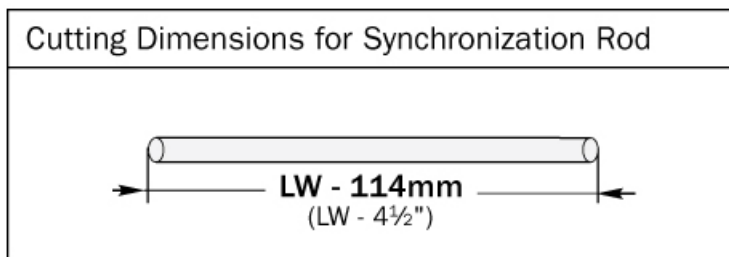

LW = Internal Cabinet Width



Technical Documents

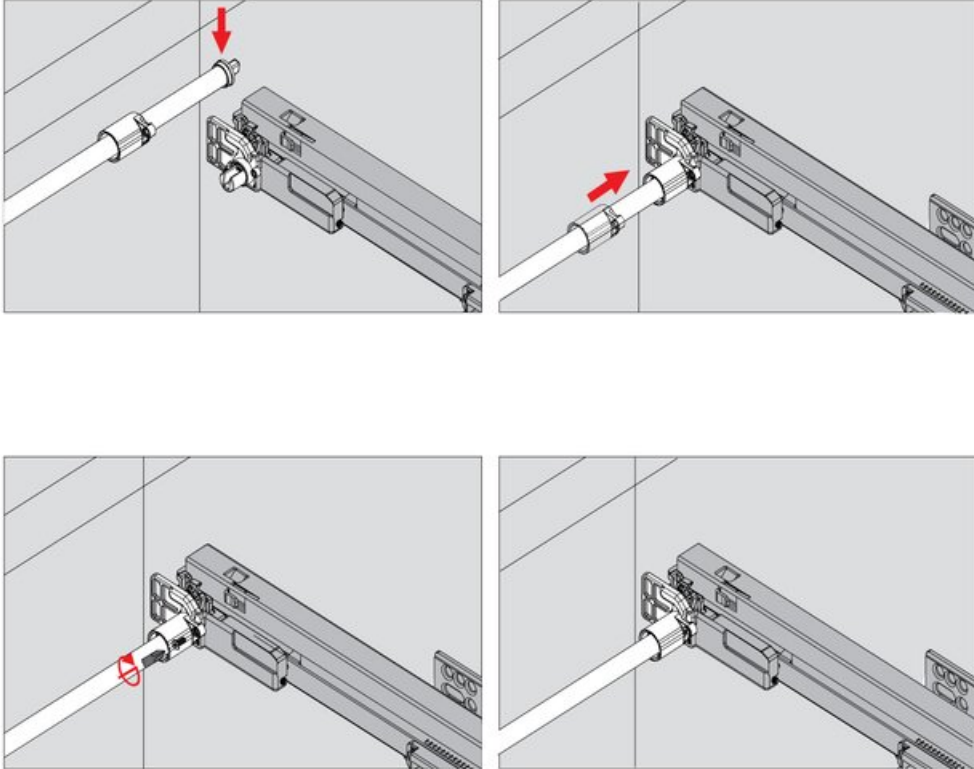

View this product online at <https://marathonhardware.com/pd/105-M51-M0FH02>



Technical Documents

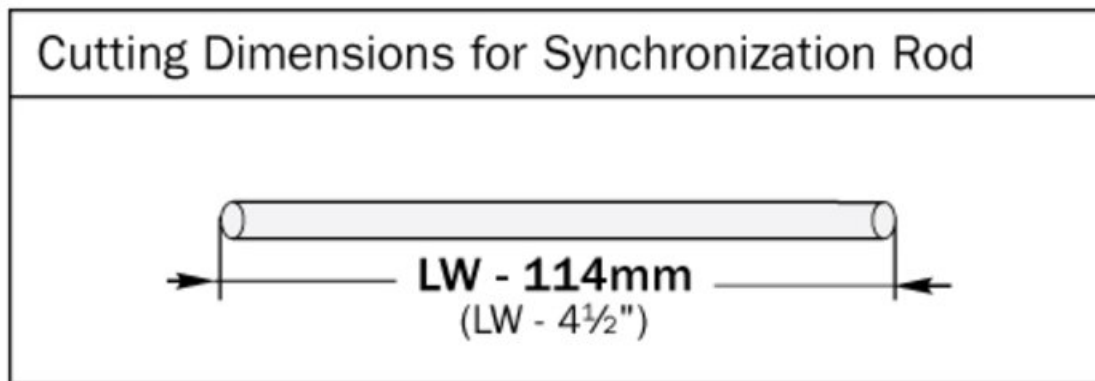

LW = Internal Cabinet Width

View this product online at <https://marathonhardware.com/pd/105-M51-M0FH02>

