

## Rear Fixing Brackets Single Rail White

**Part Number: 105-M01032W**



Rear Fixing Bracket for One Rail, White

Rear Fixing Bracket for One Lateral Rail, White Finish

Colour	White
Drawer System	Infinity Doublewall
Lateral Rail Type	Round

### Product Description

The **Doublewall Drawer Systems by DTC** are engineered and manufactured to exact specification, thus ensuring a long and reliable product lifetime that will stand up to the rigours of demanding use. We are so confident that this slide will meet or exceed your needs, that they carry a **limited lifetime warranty** on product failure and craftsmanship. In addition, they have been **certified by independent testing** and certification agencies to **exceed the highest of European and American standards** for slides.

As the exclusive distributor of DTC's products in Canada, we have the **Doublewall Drawer System** in a range of styles as needed for your application. Available in white, grey and stainless steel finishes. There are a number of optional items to provide boxesides, lateral rails or other accessories. All **Doublewall Drawer Systems** slides include as standard our Infinity Soft-Closing System for that effortless and silent close.

### Product Advantages

- Covered under Limited Lifetime Warranty
- Exceeds European/American standards
- Infinity Soft-Closing System
- Tool-less assembly/removal



## Technical Documents

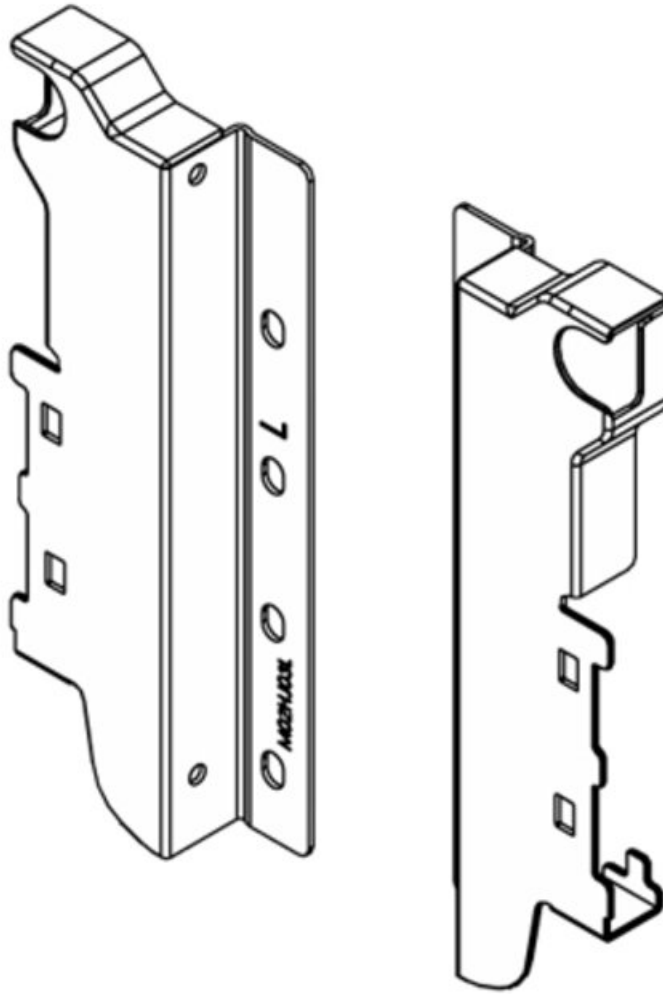

View this product online at <https://marathonhardware.com/pd/105-M01032W>

