





## Doublewall Deep Drawer, Regular Boxside with 1 Square Rail and 115 mm Drawer Height

Part Number: **webkit24693**

	Included in this webkit	Qty Required
	Double Wall System 550mm White <b>Part #: 105-MA550W-115</b>	1
	115mm Rear Fixing Brackets Single Rail <b>Part #: 105-M02032W-115</b>	1
	Lateral Rails Square 550mm White E/D <b>Part #: 105-M41P550W</b>	1

Doublewall Deep Drawer, Regular Boxside with 1 Square Rail and 115 mm Drawer Height

Boxside	-----	1 Square Rail
Closing Type	-----	Soft-Close
Colour	-----	White
Doublewall Drawer Type	-----	Standard
Drawer Height	-----	115 mm
Drawer Side Height	-----	115 mm
Drawer System	-----	Infinity Doublewall
Drawer Type	-----	Standard Drawer
Lateral Rail Type	-----	Square
Length	-----	550mm (22in)
Load Capacity	-----	40kg (88lbs)
Slide Extension Type	-----	Full-Extension

### Product Description

The **Doublewall Drawer Systems by DTC** are engineered and manufactured to exact specifications, ensuring a long and reliable product lifetime that will stand up to the rigours of demanding use. We are so confident that this slide will meet or exceed your needs that we offer a **limited lifetime warranty** on product failure and craftsmanship. In addition, they have been **certified by independent testing** and certification agencies to **exceed the highest of European and American standards** for slides.

As the exclusive distributor of DTC's products in Canada, we have the **Doublewall Drawer System** in a range of styles as needed for your application. Available in white, grey and stainless steel finishes. There are a number of optional items to provide boxsides, lateral rails or other accessories. All **Doublewall Drawer Systems** slides include as standard our Infinity Soft-Closing System for that effortless and silent close.

## Product Advantages

- Covered under Limited Lifetime Warranty
  - Exceeds European/American standards
  - Infinity Soft-Closing System
  - Tool-less assembly/removal
-

Technical Documents

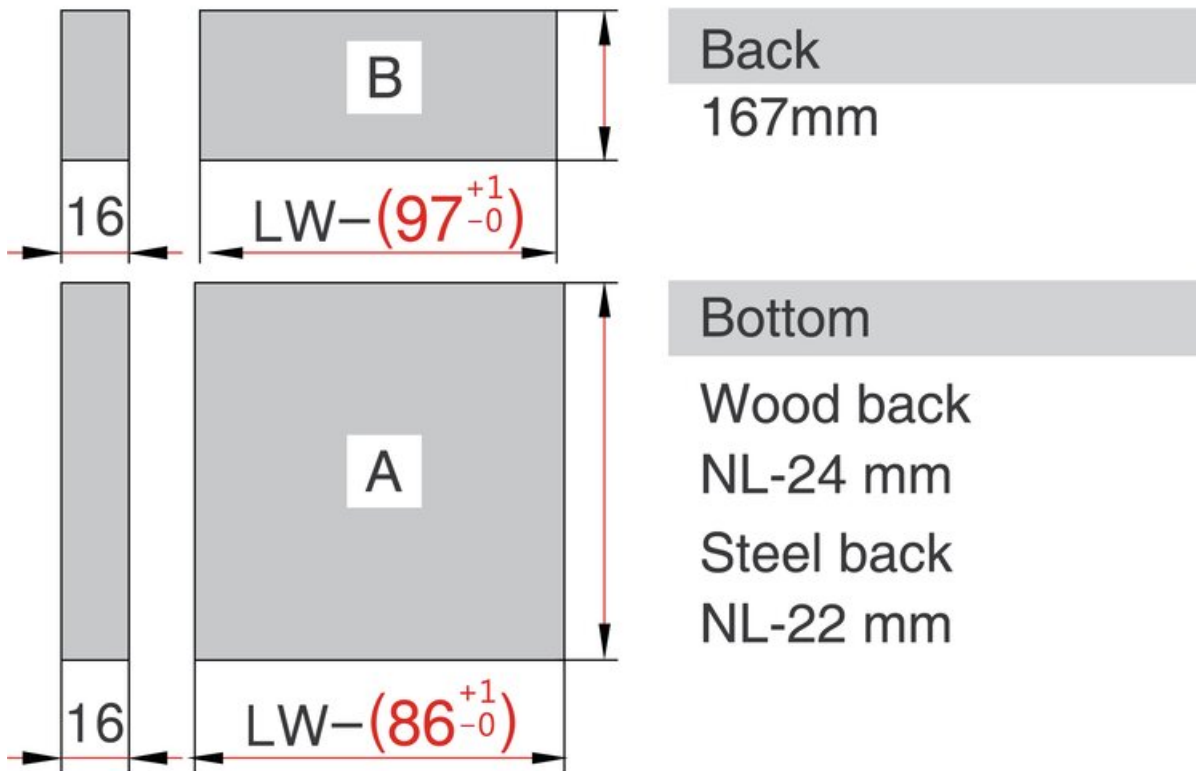

View this product online at <https://marathonhardware.com/pd/webkit24693>



## Drawer Front

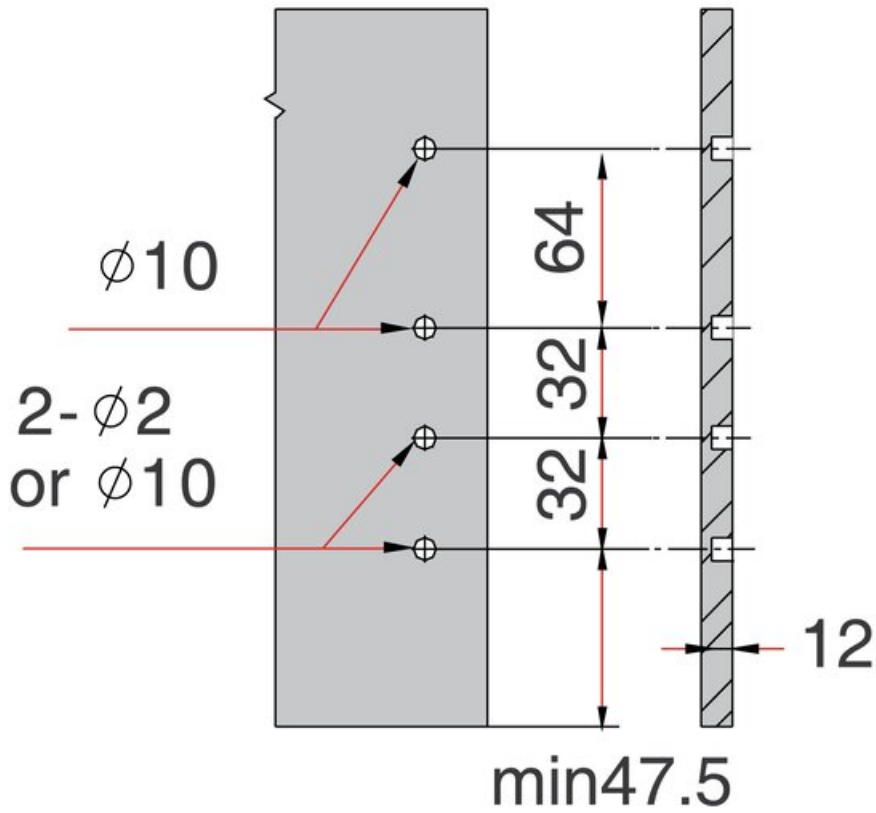

View this product online at <https://marathonhardware.com/pd/webkit24693>



## Technical Documents

LW=Internal Cabinet Width

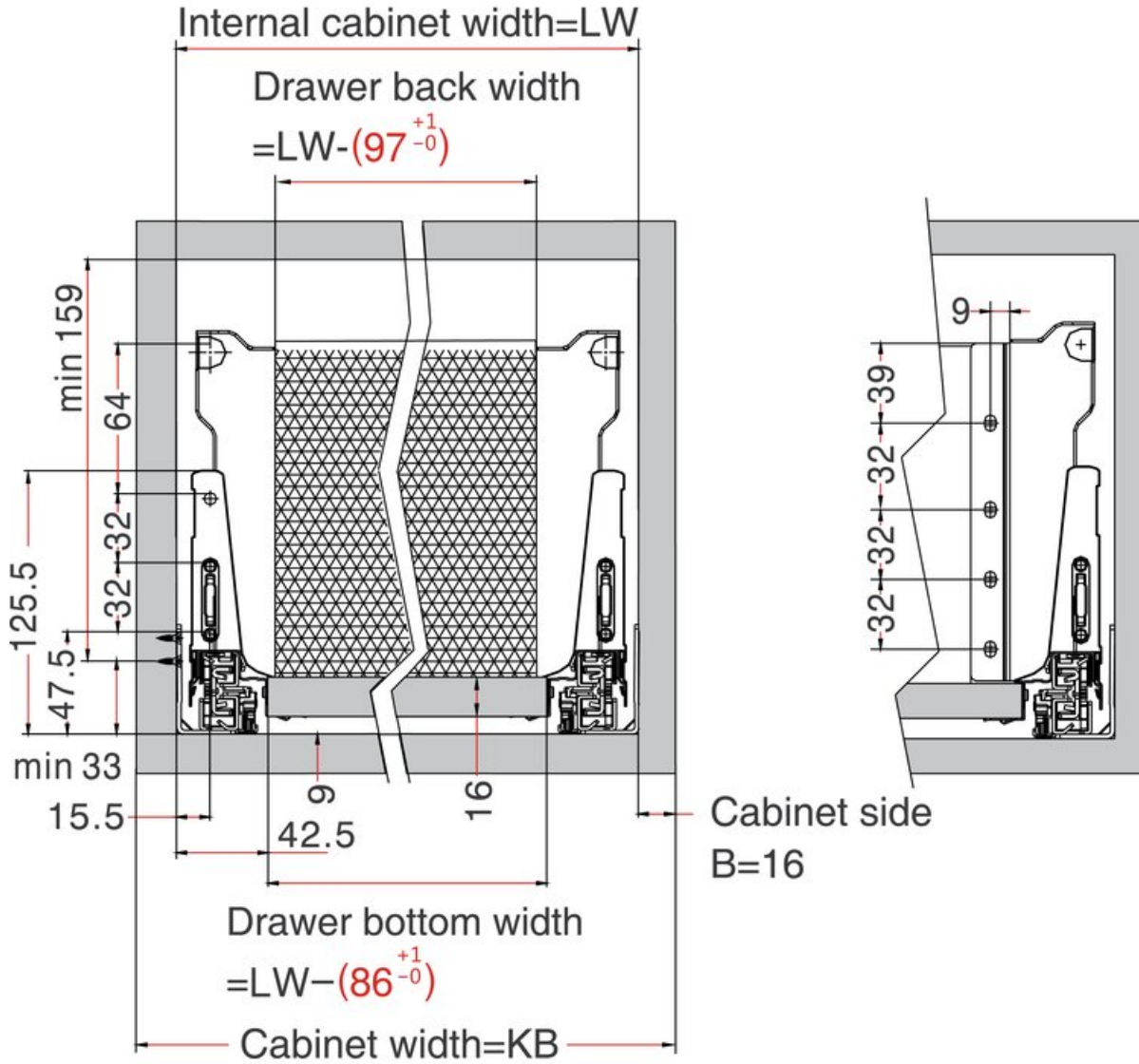

View this product online at <https://marathonhardware.com/pd/webkit24693>

Technical Documents

NL=Nominal Slide Length  
LT=Internal Cabinet Depth  
LT=NL+3

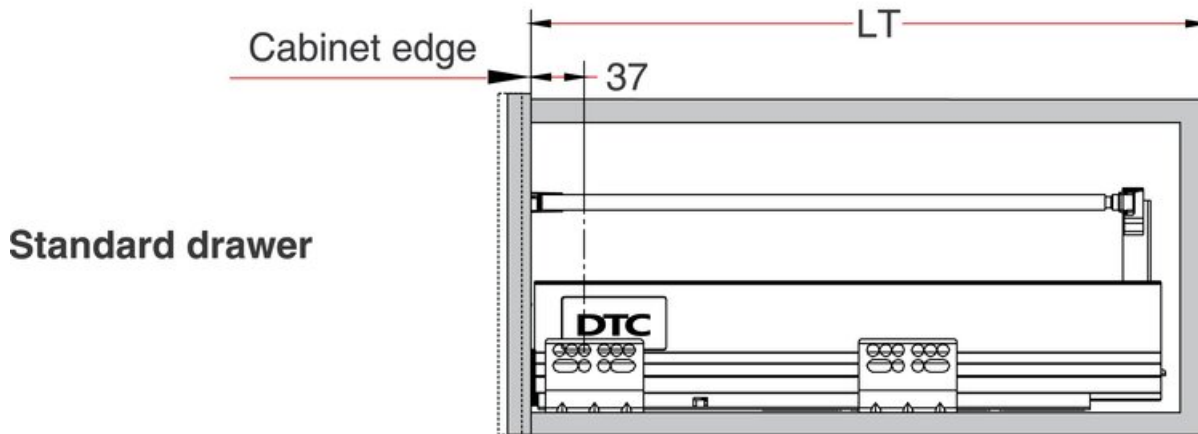

View this product online at <https://marathonhardware.com/pd/webkit24693>



## Technical Documents

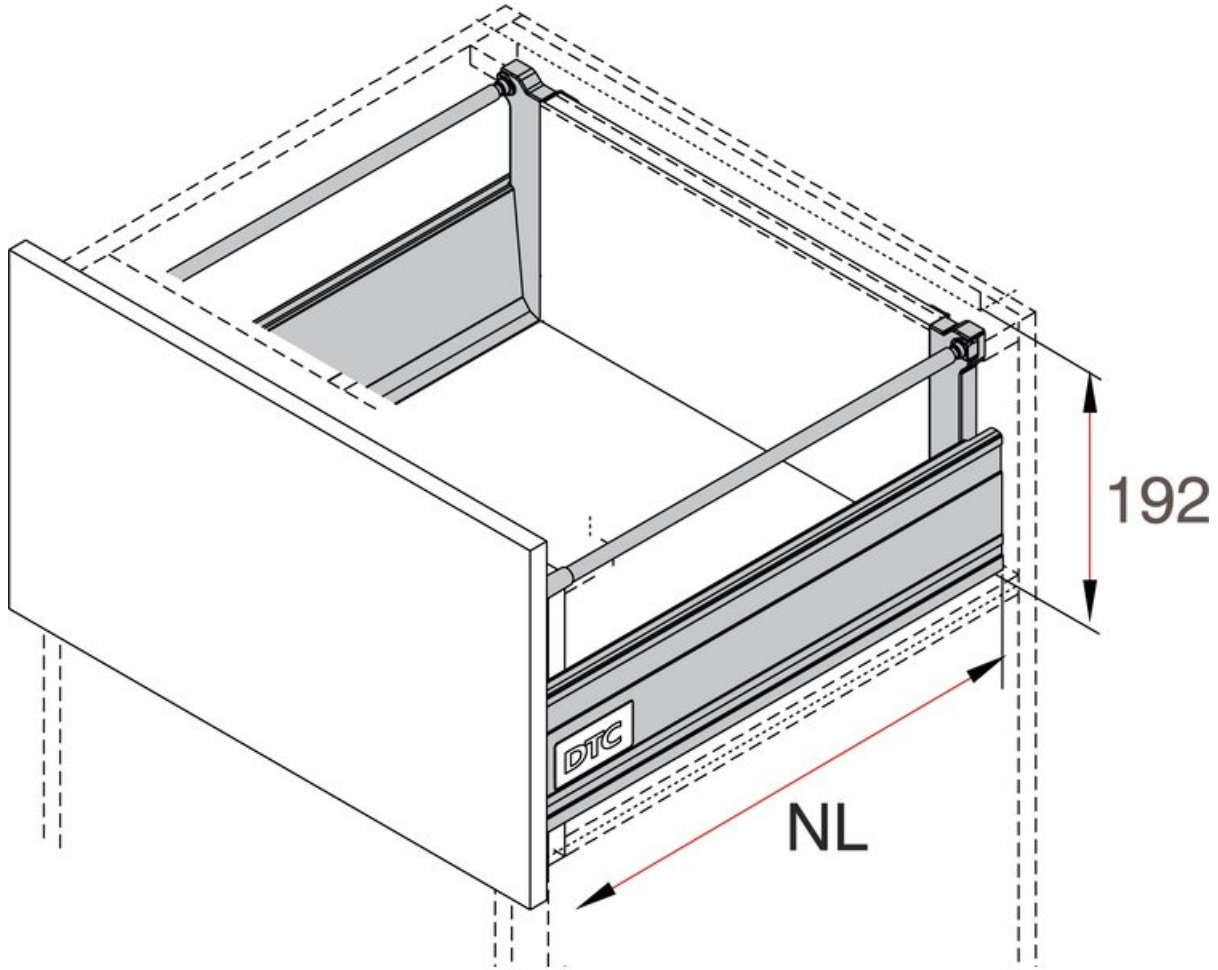

View this product online at <https://marathonhardware.com/pd/webkit24693>



## Technical Documents

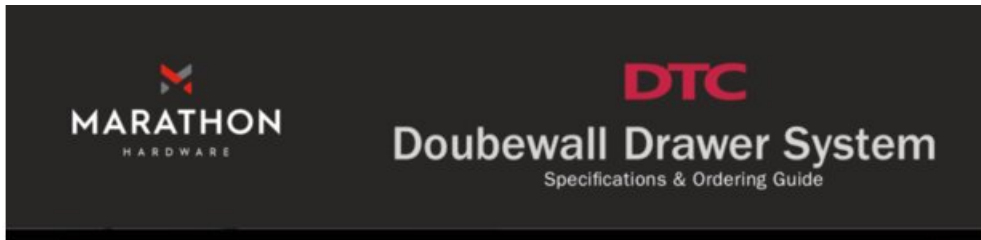

### 115mm Standard Drawer Kit

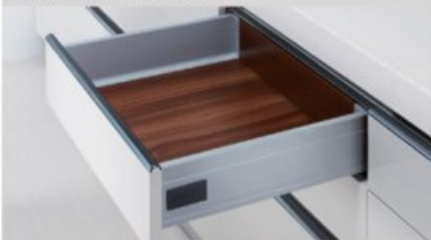

Standard Drawer Kit (packaged as a complete set)

### Product Features:

- Finishes: Grey, & White
- Tool free assembly and removal of drawer
- Silent system guarantees smooth running
- Full adjustment (up, down, left, right)
- Standard 83mm height sides
- Dynamic load capacity: 40kg

### 115mm Standard Drawer Kit Includes:

- One pair of Full Extension Soft-Close Slides
- One pair of Doublewall Drawer Slides (83mm height) and Infinity Cover Caps
- One Pair fo rear fixing brackets
- Two universal drawer front connectors



### 115mm Standard Drawer Kit Ordering Guide

Length (mm)	Length (Inch)	Grey	White
270mm	11"	105-MA270G-115	105-MA270W-115
300mm	12"	105-MA300G-115	105-MA300W-115
350mm	14"	105-MA350G-115	105-MA350W-115
400mm	16"	105-MA400G-115	105-MA400W-115
450mm	18"	105-MA450G-115	105-MA450W-115
500mm	20"	105-MA500G-115	105-MA500W-115
550mm	22"	105-MA550G-115	105-MA550W-115

800 840 1228 · MARATHONHARDWARE.COM

View this product online at <https://marathonhardware.com/pd/webkit24693>





## Technical Documents

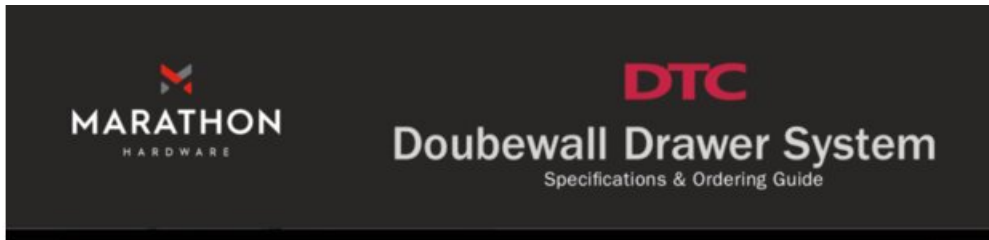

Deep Drawer, 115mm Height ,with Single Lateral Rails



**Product Features:**

- Finishes: Grey, & White
- Tool free assembly and removal of drawer
- Silent system guarantees smooth running
- Full adjustment (up, down, left, right)
- Standard 115mm height sides
- Dynamic load capacity: 40kg

Standard Drawer Kit (packaged as a complete set)

**Order Standard Drawer Kit with 115mm height sides, plus these parts:**

- Add a pair of rear single rail fixing brackets for 115mm height sides
- Add a pair of round lateral rails



Round Lateral Rails				Rear Fixing Brackets for Single Rail		
Length	Grey	White	Qty:	Finish	Part#	Qty:
270mm	105-M41E270G	105-M41E270W	60	Grey	105-M02032G	20
300mm	105-M41E300G	105-M41E300W	60	White	105-M02032W	20
350mm	105-M41E350G	105-M41E350W	60			
400mm	105-M41E400G	105-M41E400W	60			
450mm	105-M41E450G	105-M41E450W	60			
500mm	105-M41E500G	105-M41E500W	60			
550mm	105-M41E550G	105-M41E550W	60			



800 840 1228 · MARATHONHARDWARE.COM

View this product online at <https://marathonhardware.com/pd/webkit24693>

