



Double Wall Push System 350mm White

Part Number: 105-M51-350W

Doublewall Drawer System - Infinity Push System

Available in both Grey and White Finishes

<div>
</div>

Boxside	None
Closing Type	Push-Open
Colour	White
Doublewall Drawer Type	Push Open
Drawer Side Height	83 mm
Drawer System	Infinity Doublewall
Drawer Type	Standard Drawer
Lateral Rail Type	No Rail
Length	350mm (14in)
Load Capacity	40kg (88lbs)
Slide Extension Type	Full-Extension

Product Description

The **Doublewall Drawer Systems by DTC** are engineered and manufactured to exact specification, thus ensuring a long and reliable product lifetime that will stand up to the rigours of demanding use. We are so confident that this is slide will meet or exceed your needs, that they carry a **limited lifetime warranty** on product failure and craftsmanship. In addition, they have been **certified by independent testing** and certification agencies to **exceed the highest of European and American standards** for slides.

As the exclusive distributor of DTC's products in Canada, we have the **Doublewall Drawer System** in a range of styles as needed for your application. Available in white, grey and stainless steel finishes. There are a number of optional items to provide boxsides, lateral rails or other accessories. These **Doublewall Drawer Systems** slides include our Infinity Push System for a seamless push system with rebound opening.

Product Advantages

- Covered under Limited Lifetime Warranty
- Exceeds European/American standards
- Newly redesigned Push System with rebound
- Compatible with Doublewall System accessories
- Tool-less assembly/removal

Important Information

- Recommend using Sync Rod for drawers wider than 400mm
-

Included Products

Doublewall Drawer Kits include:

- One pair of full extension Infinity Push slides
 - One pair of doublewall drawer sides (83mm height)
 - One pair of Infinity Push Systems cover caps
 - One pair of rear fixing brackets
 - Two universal drawer front connectors
-

Technical Documents

Installation Dimensions for Infinity Push System

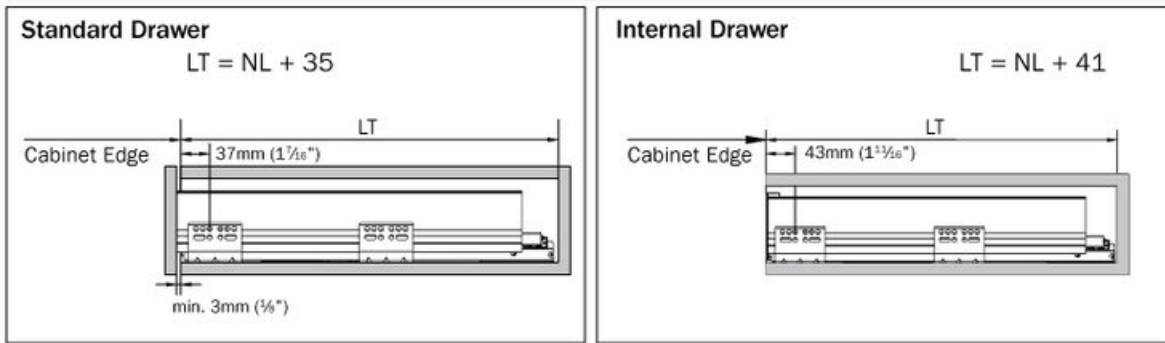

LT = Internal Cabinet Depth

NL = Slide Nominal Length

View this product online at <https://marathonhardware.com/pd/105-M51-350W>



Technical Documents

DRAWER ADJUSTMENT INSTRUCTIONS



1. Remove cover cap on both sides of drawer.

2. Turn the up/down or left/right adjustment screws. There is a maximum of $\pm 2\text{mm}$ height and $\pm 1.5\text{mm}$ lateral adjustment possible.

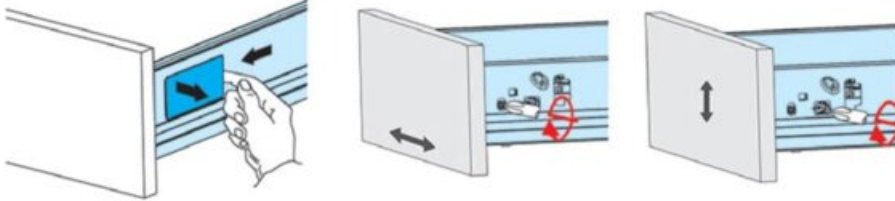

When finished with your adjustments, snap the cover caps back onto the drawer.

DRAWER REMOVAL INSTRUCTIONS



1. Remove cover cap on both sides of drawer.



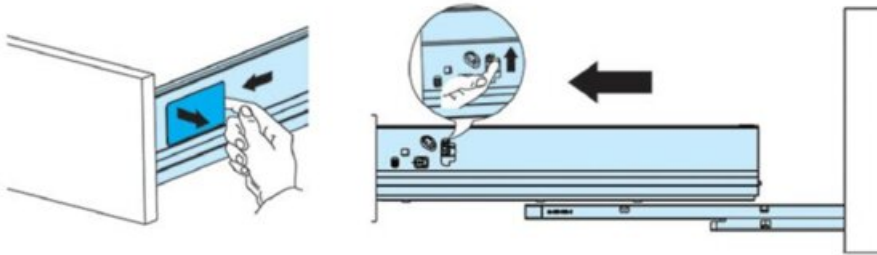







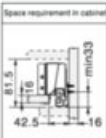
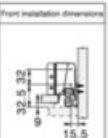
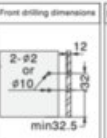
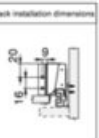
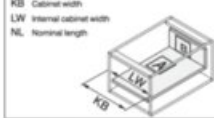
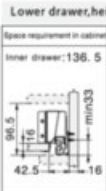
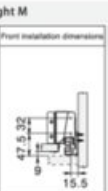
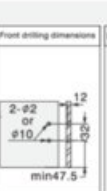
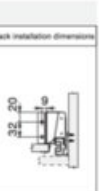
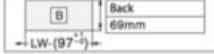
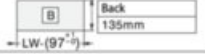
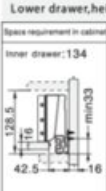
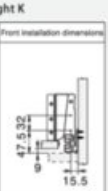
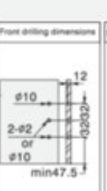
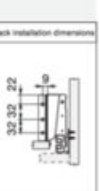
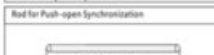

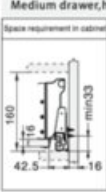
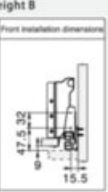
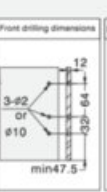
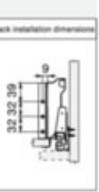
2. Use finger to release drawer on both sides and pull drawer forward to remove from slide.

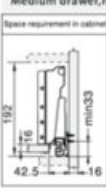
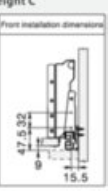
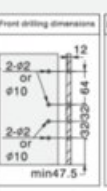
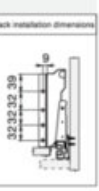

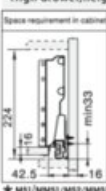
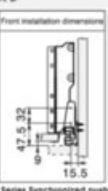
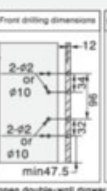
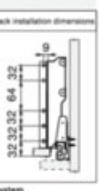
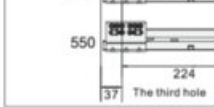
To re-install, place drawer on extended slides and push the drawer in fully. When it clicks, the lock will be engaged. Replace cover caps on both sides.

View this product online at <https://marathonhardware.com/pd/105-M51-350W>

Technical Documents

Lower drawer,height N Space requirement in cabinet:  Front installation dimensions:  Front drilling dimensions:  Back installation dimensions: 				Cutting dimensions for 16mm chipboard KB Cabinet width LW Internal cabinet width NL Nominal length  <table border="1" data-bbox="958 304 1161 420"> <tr><td>Bottom</td></tr> <tr><td>Chipboard back</td></tr> <tr><td>NL-24 mm</td></tr> <tr><td>Steel back</td></tr> <tr><td>NL-22 mm</td></tr> </table>		Bottom	Chipboard back	NL-24 mm	Steel back	NL-22 mm
Bottom										
Chipboard back										
NL-24 mm										
Steel back										
NL-22 mm										
Lower drawer,height M Space requirement in cabinet:  Inner drawer: 136.5 Front installation dimensions:  Front drilling dimensions:  Back installation dimensions: 				Lower drawer,height N  Back 69mm LW-(97 ⁻¹) Medium drawer,height B  Back 135mm LW-(97 ⁻¹)						
Lower drawer,height K Space requirement in cabinet:  Inner drawer: 134 Front installation dimensions:  Front drilling dimensions:  Back installation dimensions: 				Lower drawer,height M  Back 84mm LW-(97 ⁻¹) Medium drawer,height C  Back 167mm LW-(97 ⁻¹)						
Lower drawer,height K Space requirement in cabinet:  Inner drawer: 134 Front installation dimensions:  Front drilling dimensions:  Back installation dimensions: 				Lower drawer,height K  Back 116mm LW-(97 ⁻¹) High drawer,height D  Back 199mm LW-(97 ⁻¹)						
Medium drawer,height B Space requirement in cabinet:  Front installation dimensions:  Front drilling dimensions:  Back installation dimensions: 				Rad for Push-open Synchronization  LW-114 Front section for inner drawer  LW-97						
Medium drawer,height C Space requirement in cabinet:  Front installation dimensions:  Front drilling dimensions:  Back installation dimensions: 				Installation dimensions Internal cabinet Depth = LT LT = NL + 35  Cabinet edge Internal cabinet Depth = LT LT = NL + 41  Cabinet edge min 3 Inner drawer						
High drawer,height D Space requirement in cabinet:  Front installation dimensions:  Front drilling dimensions:  Back installation dimensions: 				Screw Positions of the Slides  Cabinet edge NL 270 300 350 400 450 500 550 224 37 The third hole						

★ M51/M51/M52/M53 Series Synchronized push-open double-wall drawer system



302712284-01760

View this product online at <https://marathonhardware.com/pd/105-M51-350W>

