



## Double Wall Undersink 550mm St. Steel

**Part Number: 105-M01550G-SS**

### Undersink Kits

Boxside	None
Closing Type	Infinity Soft-Close
Colour	Stainless Steel
Doublewall Drawer Type	Undersink
Drawer Side Height	83 mm
Drawer System	Infinity Doublewall
Drawer Type	Undersink Drawer
Lateral Rail Type	No Rail
Length	550mm (22in)
Load Capacity	40kg (88lbs)
Slide Extension Type	Full Extension

## Product Description

The **Doublewall Drawer Systems by DTC** are engineered and manufactured to exact specifications, ensuring a long and reliable product lifetime that will stand up to the rigours of demanding use. We are so confident that this slide will meet or exceed your needs that we offer a **limited lifetime warranty** on product failure and craftsmanship. In addition, they have been **certified by independent testing** and certification agencies to **exceed the highest of European and American standards** for slides.

As the exclusive distributor of DTC's products in Canada, we have the **Doublewall Drawer System** in a range of styles as needed for your application. Available in white, grey and stainless steel finishes. There are a number of optional items to provide boxsides, lateral rails or other accessories. All **Doublewall Drawer Systems** slides include as standard our Infinity Soft-Closing System for that effortless and silent close.

## Product Advantages

- Covered under Limited Lifetime Warranty
- Exceeds European/American standards
- Infinity Soft-Closing System
- Tool-less assembly/removal

Technical Documents

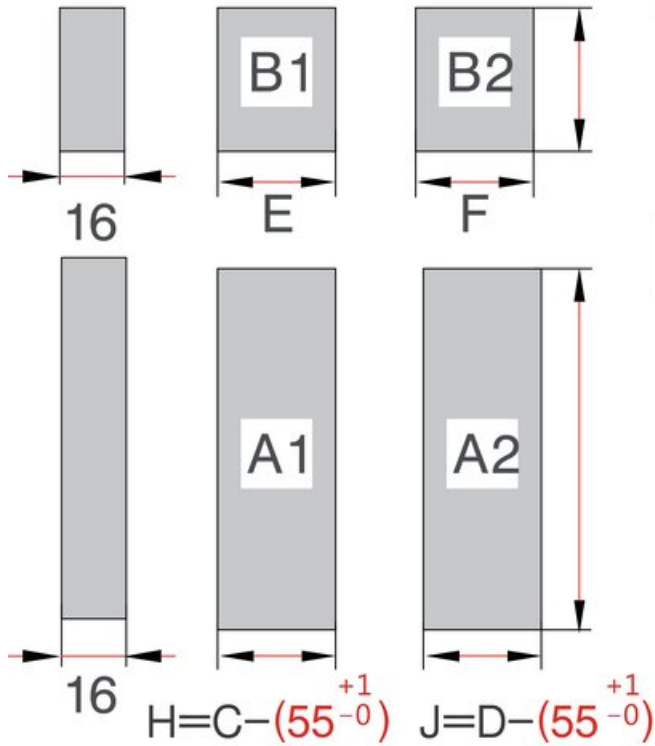

Back

84mm

Bottom

Wood back

NL-24 mm

View this product online at <https://marathonhardware.com/pd/105-M01550G-SS>

Technical Documents

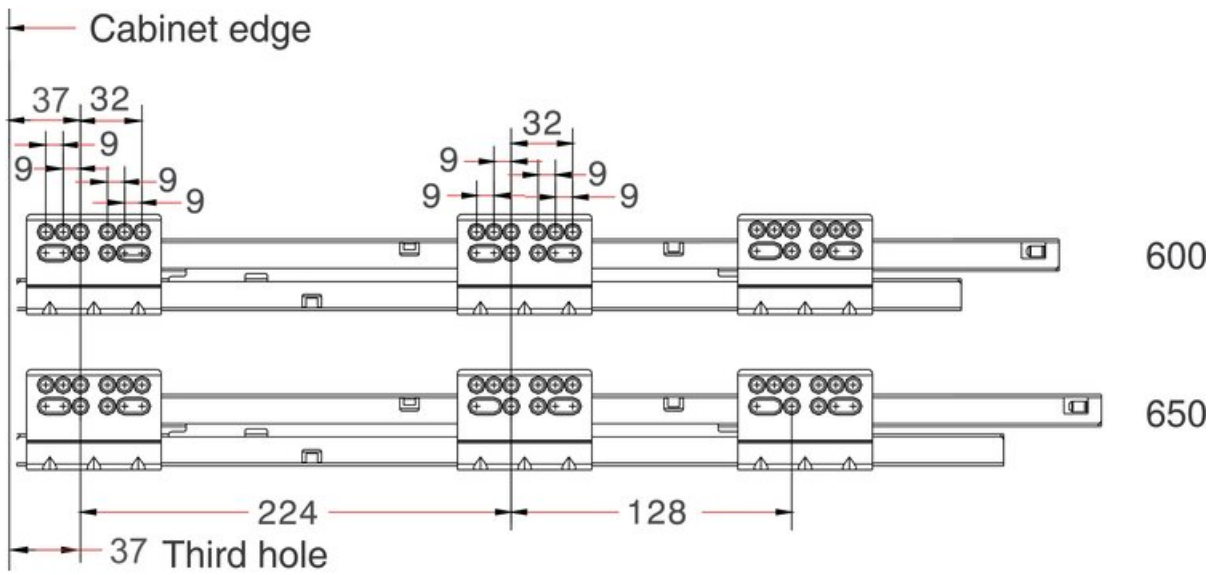

View this product online at <https://marathonhardware.com/pd/105-M01550G-SS>

Drawer Front

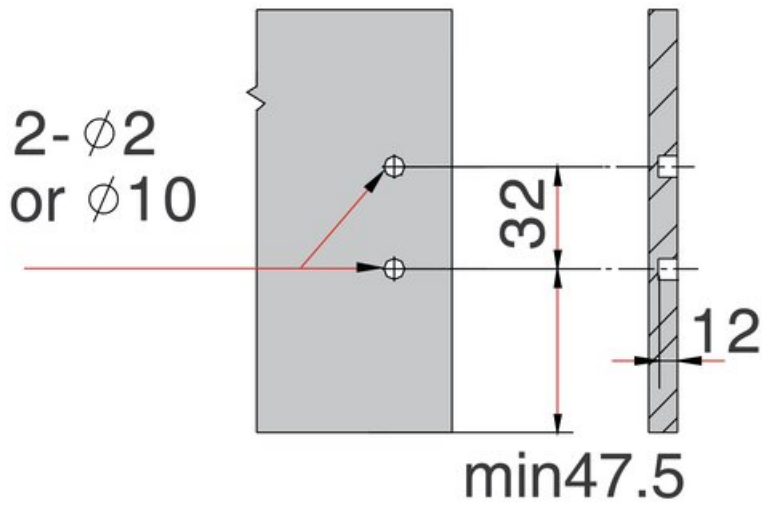

View this product online at <https://marathonhardware.com/pd/105-M01550G-SS>

Technical Documents

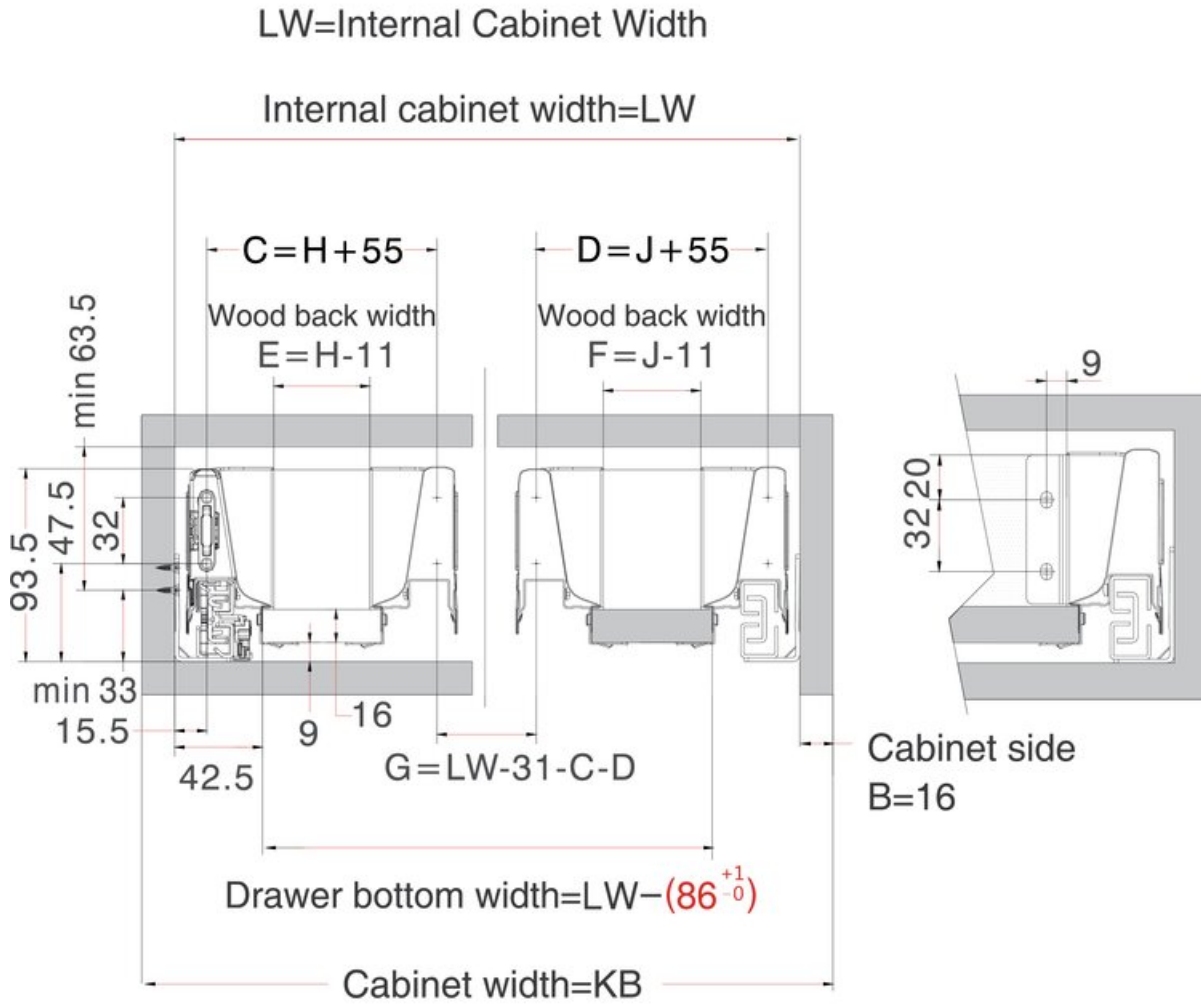

View this product online at <https://marathonhardware.com/pd/105-M01550G-SS>

Technical Documents

NL=Nominal Slide Length  
LT=Internal Cabinet Depth  
LT=NL+3

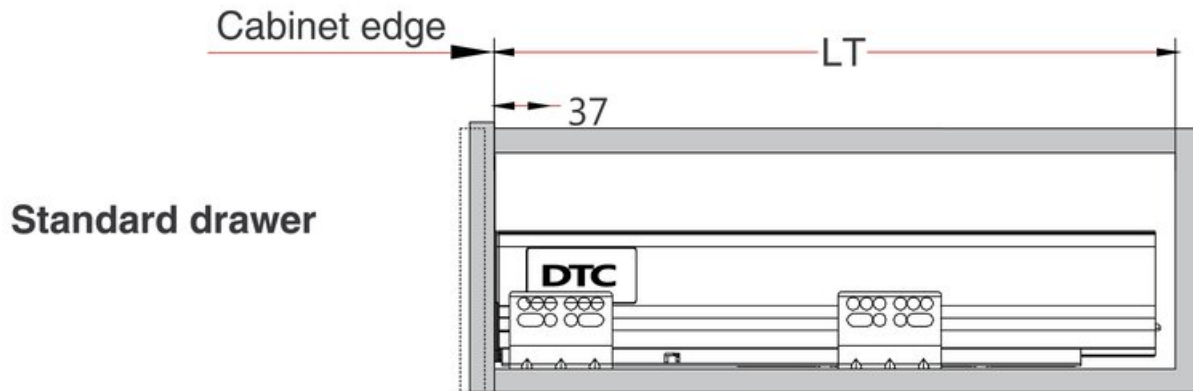

View this product online at <https://marathonhardware.com/pd/105-M01550G-SS>



## Technical Documents

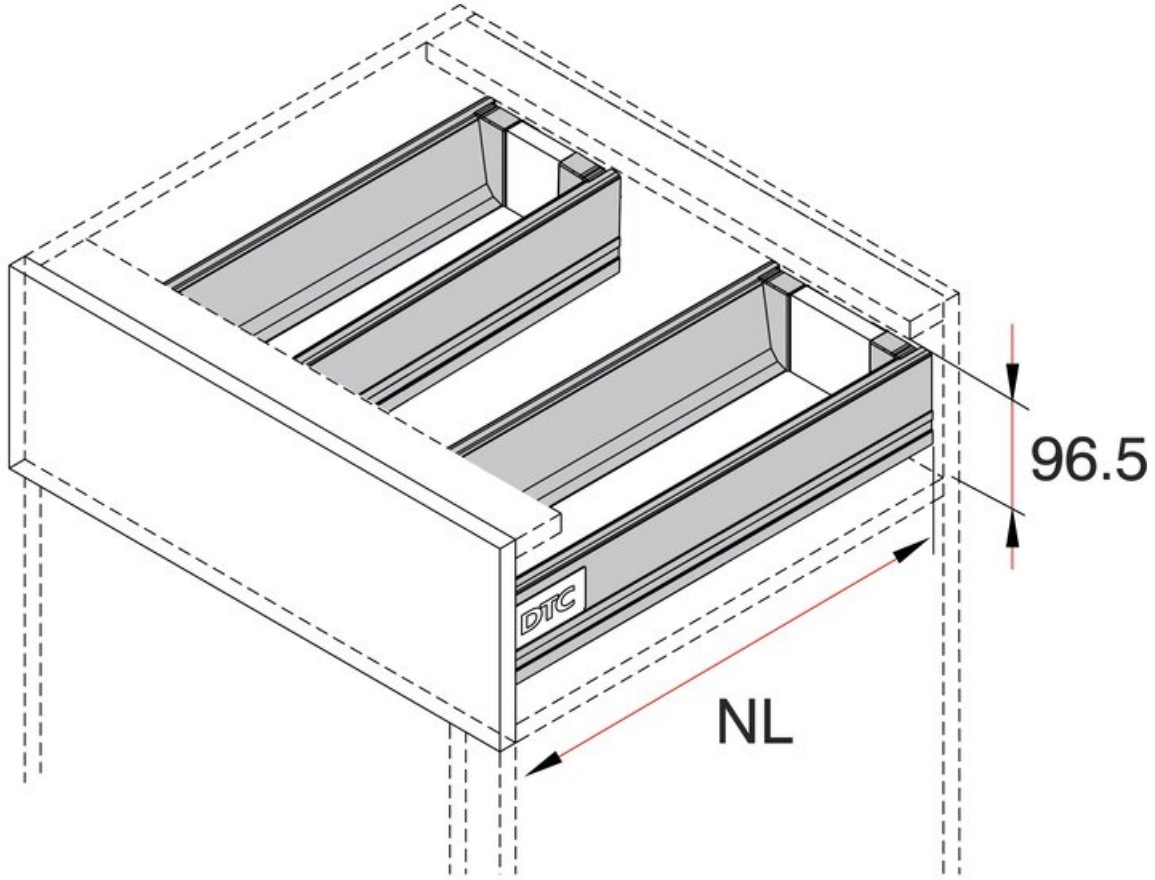

NL:Nominal length

View this product online at <https://marathonhardware.com/pd/105-M01550G-SS>



## Technical Documents

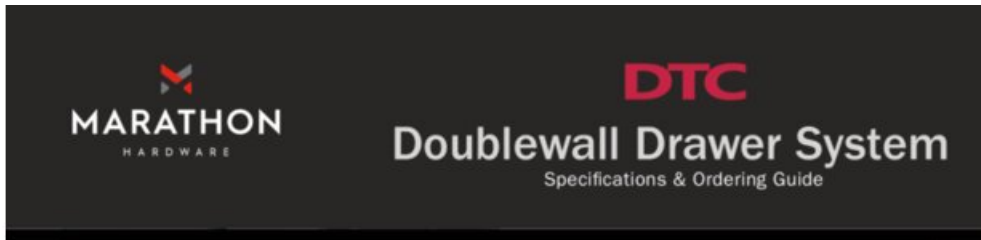

### Under Sink Drawer



Standard Drawer Kit (packaged as a complete set)

### Product Features

- Finishes: Grey, & White
- Tool free assembly and removal of drawer
- Silent system guarantees smooth running
- Full adjustment (up, down, left, right)
- Standard 83mm height sides
- Dynamic load capacity: 40kg (88lbs)

### Standard Corner Drawer 45 Degree Kit Includes:

- One pair of Full Extension Soft-Close Slides
- One pair of Doublewall Drawer Sides (83mm Height), which includes two pair of infinity cover caps
- Two pair of rear fixing brackets
- Four universal drawer front connectors

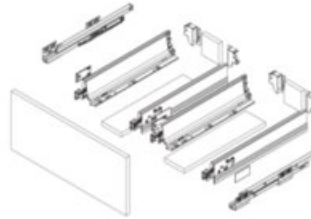

### Standard Corner Drawer Kits

Length	Grey			Qty.
600mm	105-M01500G-G	105-M010500G-W	105-M010500G-SS	20
650mm	105-M01550G-G	105-M010550G-W	105-M010550G-SS	20

800 840 1228 MARATHONHARDWARE.COM

View this product online at <https://marathonhardware.com/pd/105-M01550G-SS>



