



## Legacy Prima Drawer System 400mm Silk White, 172mm Height

**Part Number: 105-HT172-SW400**

DTC Legacy Prima Drawer System 400mm Length, 172mm Height, Silk White

Legacy Prima is a slim box drawer system featuring premium materials, technology and design. Synchronized soft-close slide with 40kg load capacity.

Closing Type	Soft-Close
Colour	Silk White
Drawer Side Height	172 mm
Drawer System	Legacy Prima
Drawer Type	Standard Drawer
Length	400mm (16in)
Load Capacity	40kg (88lbs)
Material	Premium Metal
Slide Extension Type	Full Extension
Slide Type	Synchronized

### Product Description

Legacy Prima is the new name for our existing high-quality drawer system. Available with dozens of options to fully customize your project and fit it to the exact specifications and needs of your client. Seven lengths and four available heights, including sleek and stylish glass options on two of the heights, give you the option to create a high end space designed for your client's lifestyle.

### Product Advantages

- Maximize internal storage and usable space
- Convey contemporary style and design
- Synchronized soft-close slides for ultra smooth and silent motion
- High dynamic load capacity of 40 kg (88 lbs)
- Range of colours that match and compliment today's modern looks
- 3 heights, 7 lengths and a complete range of accessories in glass and metal
- Tool-free assembly and installation
- No extra machining required on bottom panel

### Included Products

The Standard Drawers with Metal Sides are sold as a complete kit. All cabinet slides, drawer sides, back and front fixing brackets, and cover caps are included in a boxed kit. No need to order parts separately and juggle open boxes with different quantities of product remaining.



## Technical Documents

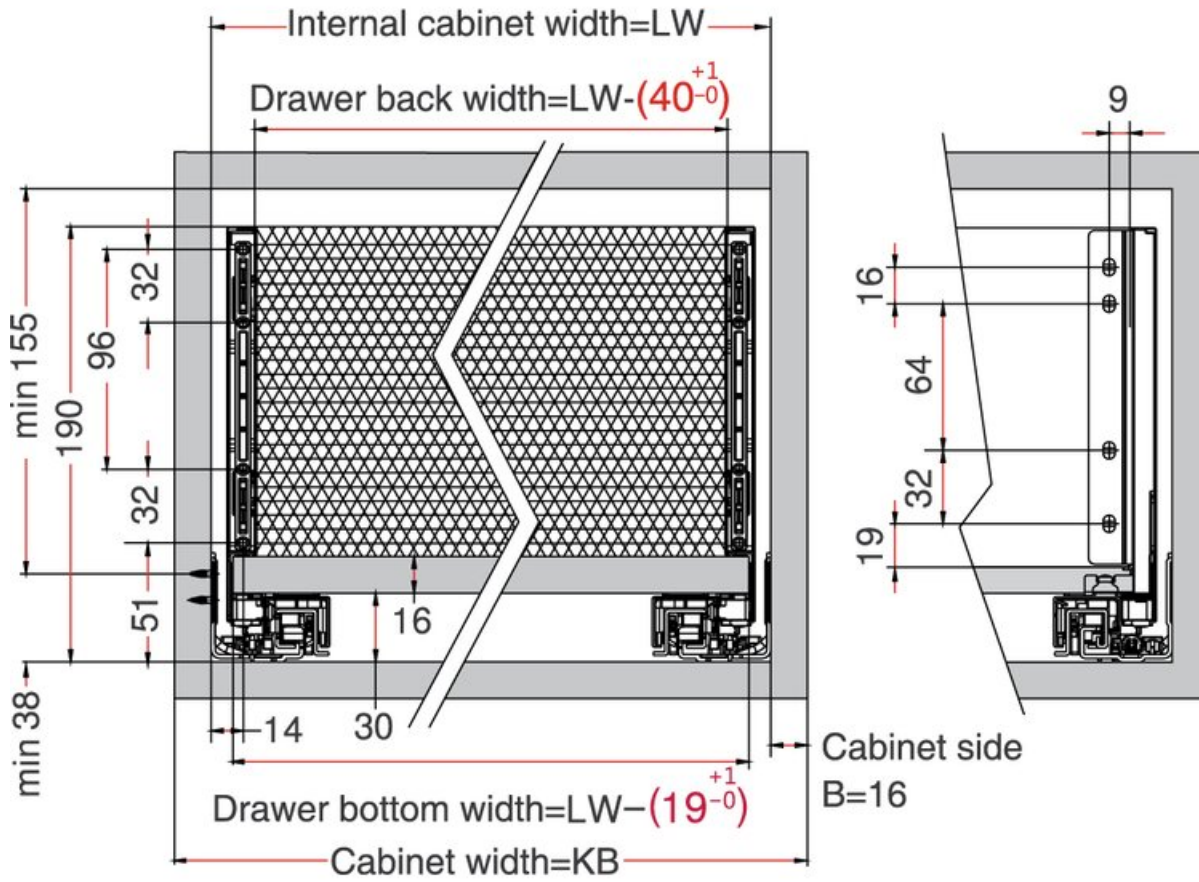

View this product online at <https://marathonhardware.com/pd/105-HT172-SW400>



## Technical Documents

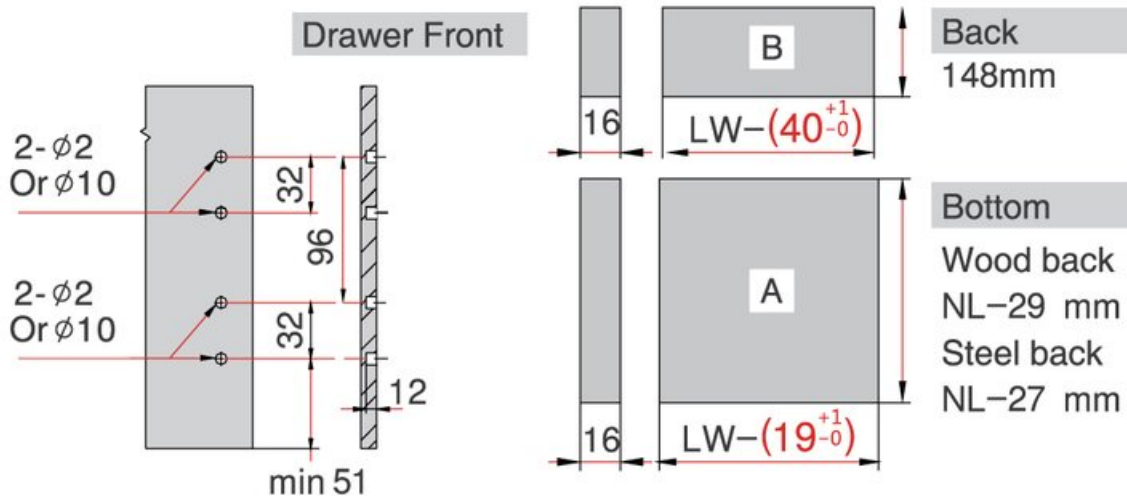

View this product online at <https://marathonhardware.com/pd/105-HT172-SW400>



## Technical Documents

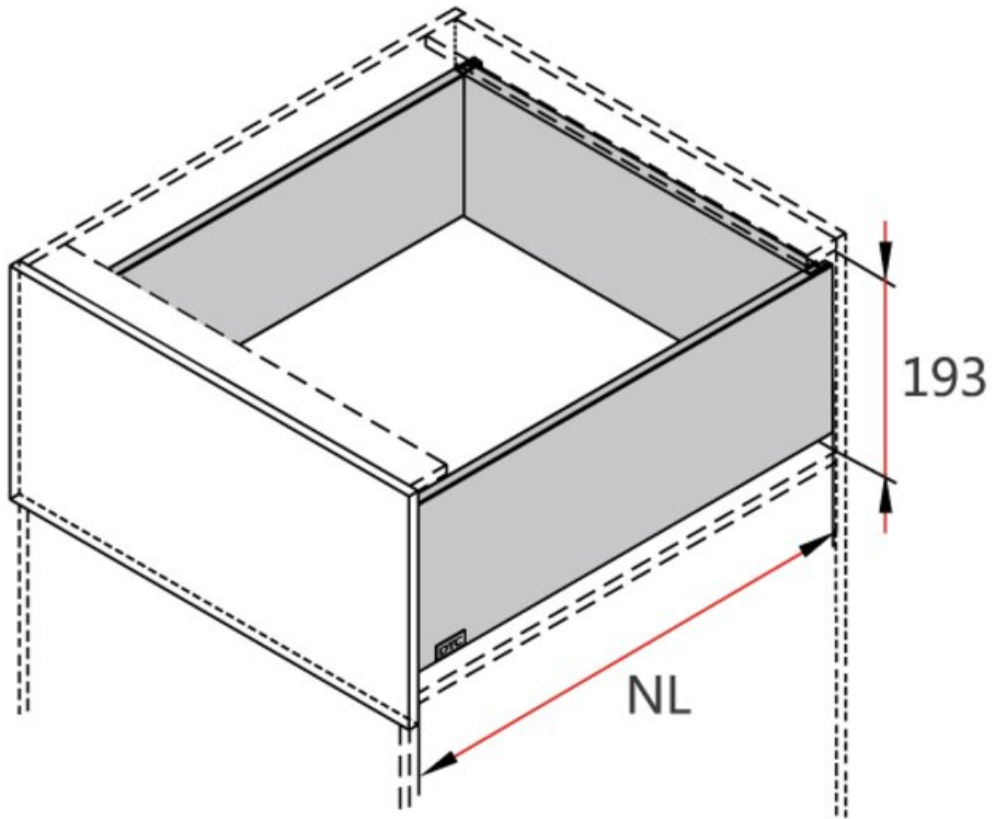

View this product online at <https://marathonhardware.com/pd/105-HT172-SW400>



## Technical Documents

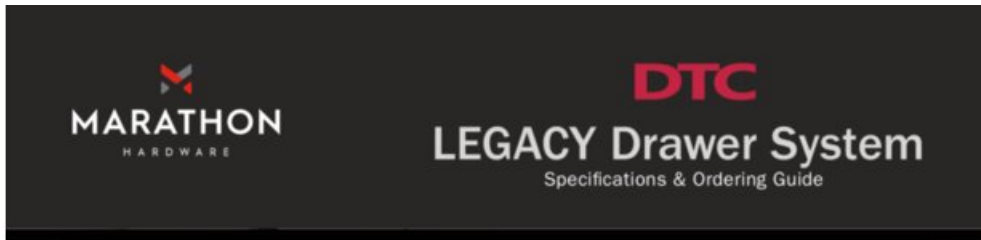

### Standard Drawer Kit, 172mm C Height

### Product Features



- Modern Straight Slim box drawer system
- Silent system guarantees quiet, smooth run
- High dynamic load capacity: 40/60kg (88/132lbs)
- Concealed slide with full extension
- Tool free assembly and removal of drawer
- 3D Adjustment

### Standard Drawer Kit (packaged as a complete set)

- One pair of Full Extension Soft-Close Slides
- One pair of Legacy Drawer Sides (172mm C Height)
- One set of inner/outer cover caps
- One pair of rear fixing brackets
- Two universal drawer front connectors (with dowel)

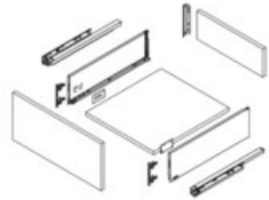

### Standard Drawer Kit (Matte Grey) Ordering Guide

Length (mm)	Length (Inch)	Grey Matte	Silk White
270mm	11"	105-HT172-GM270	105-HT172-SW270
300mm	12"	105-HT172-GM300	105-HT172-SW300
350mm	14"	105-HT172-GM350	105-HT172-SW350
400mm	16"	105-HT172-GM400	105-HT172-SW400
450mm	18"	105-HT172-GM450	105-HT172-SW450
500mm	20"	105-HT172-GM500	105-HT172-SW500
550mm	22"	105-HT172-GM550	105-HT172-SW550

800 840 1228 · MARATHONHARDWARE.COM

View this product online at <https://marathonhardware.com/pd/105-HT172-SW400>

