







## Legacy Prima Internal Glass Front and Glass Sides Drawer, 88mm Height, 400 mm Length, 1000 mm Width, Silk White

**Part Number: webkit-legacy77728**

	Included in this webkit	Qty Required
	Legacy Prima Glass Drawer System 400mm Silk White <b>Part #: 105-HG88-SW400</b>	1
	Boxsides 400mm Glass <b>Part #: 105-HG88-CGL400</b>	1
	Internal Drawer Front 1000mm Glass <b>Part #: 105-HG46-GL1000</b>	1
	Front Fixing Brackets Silk White <b>Part #: 105-HT11013-SW</b>	1
	Drawer Front Internal 1100mm Silk White, Short <b>Part #: 105-HT10021-SW</b>	1

Legacy Prima is a slim box drawer system featuring premium materials, technology and design. Synchronized soft-close slide with 40kg load capacity.

Closing Type	Soft-Close
Colour	Silk White
Drawer Side Height	88 mm
Drawer System	Legacy Prima
Drawer Type	Internal Drawer
Length	400mm (16in)
Load Capacity	40kg (88lbs)
Material	Premium Metal
Slide Extension Type	Full Extension
Slide Type	Synchronized
Width	1000 mm

## Product Description

Legacy Prima is the new name for our existing high-quality drawer system. Available with dozens of options to fully customize your project and fit it to the exact specifications and needs of your client. Seven lengths and four available heights, including sleek and stylish glass options on two of the heights, give you the option to create a high end space designed for your client's lifestyle.

---

## Product Advantages

- Maximize internal storage and usable space
  - Convey contemporary style and design
  - Synchronized soft-close slides for ultra smooth and silent motion
  - High dynamic load capacity of 40 kg (88 lbs)
  - Range of colours that match and compliment today's modern looks
  - 3 heights, 7 lengths and a complete range of accessories in glass and metal
  - Tool-free assembly and installation
  - No extra machining required on bottom panel
- 

## Important Information

The Width listed for each Internal Glass Front should be used to specify the precise External Cabinet Width in millimeters that is needed for installation of a properly constructed and assembled drawer box.

---



## Technical Documents

### Drawer Front

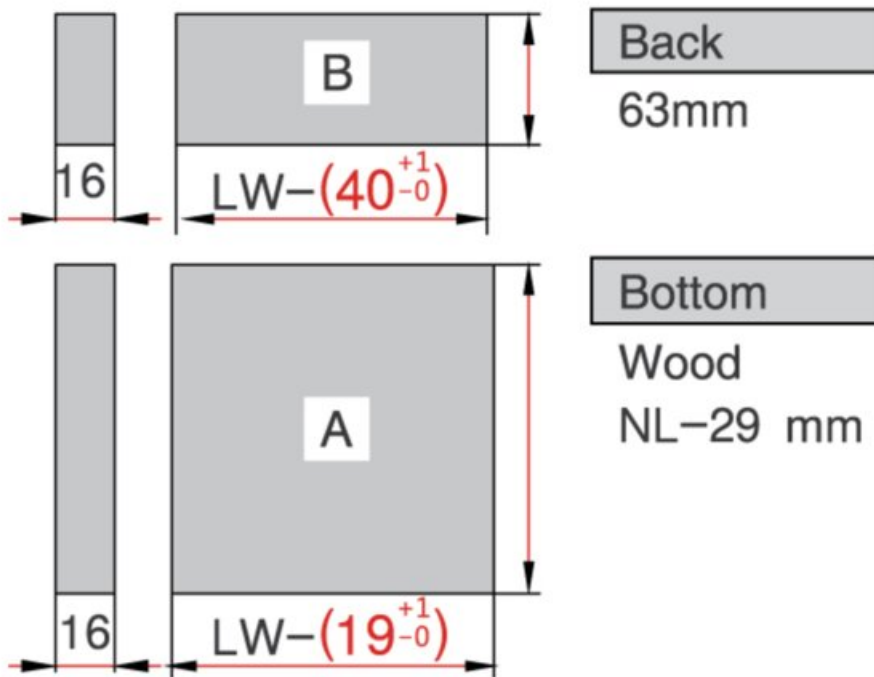
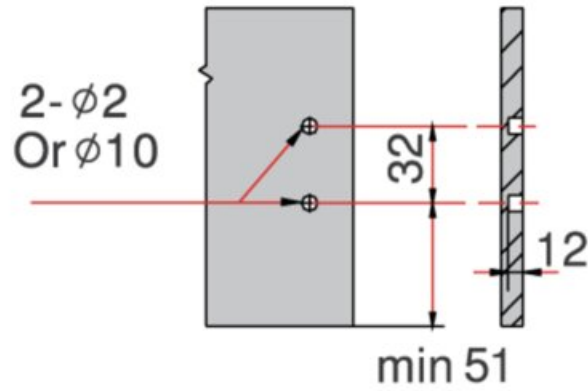

View this product online at <https://marathonhardware.com/pd/webkit-legacy77728>

Technical Documents

LW=Internal Cabinet Width

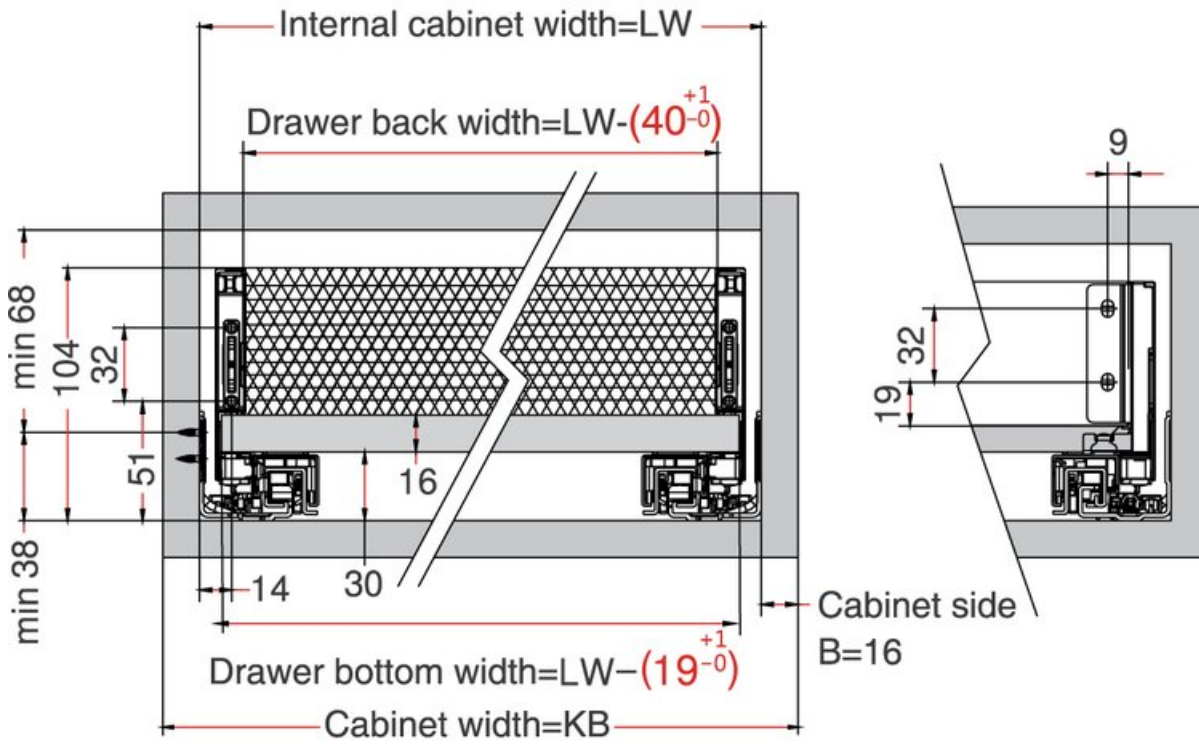

View this product online at <https://marathonhardware.com/pd/webkit-legacy77728>



## Technical Documents

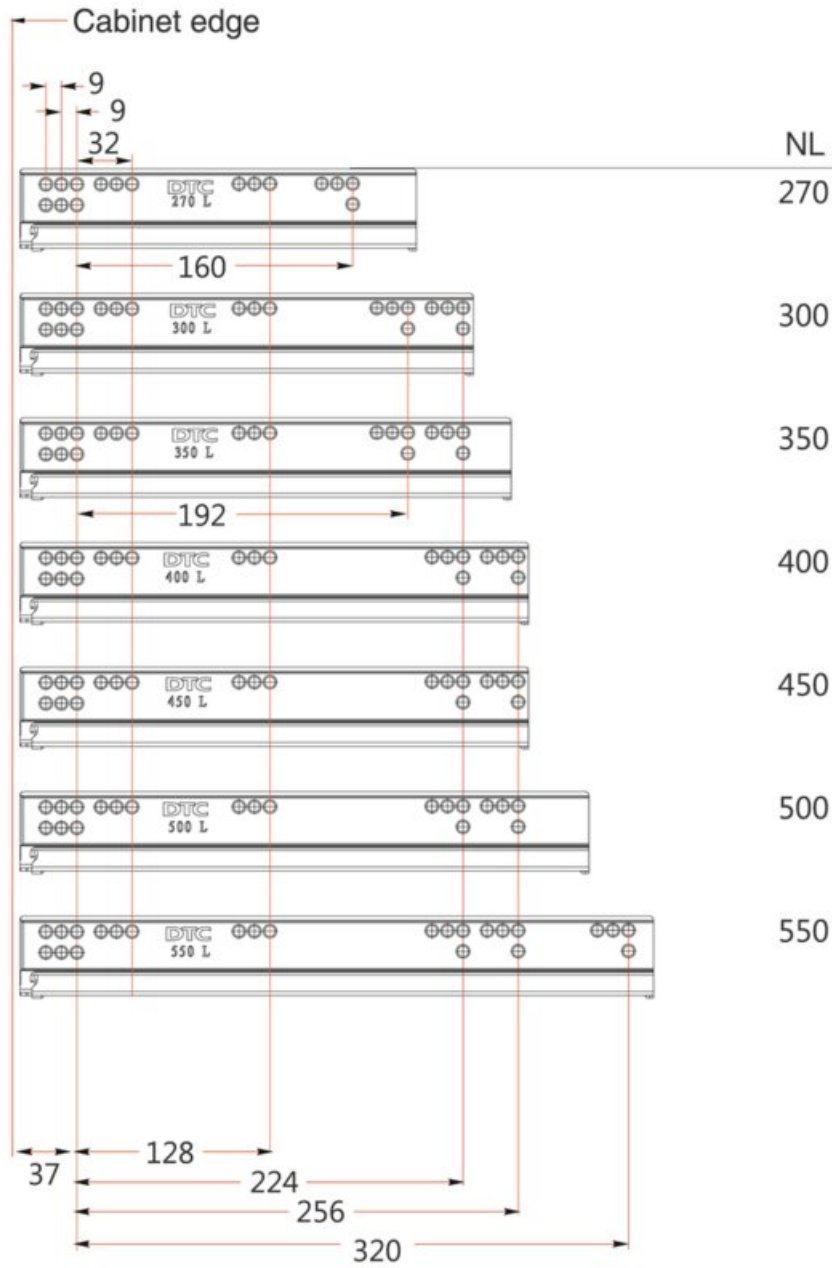

View this product online at <https://marathonhardware.com/pd/webkit-legacy77728>

Technical Documents

NL=Nominal Slide Length  
LT=Internal Cabinet Depth  
 $LT = NL + 3$

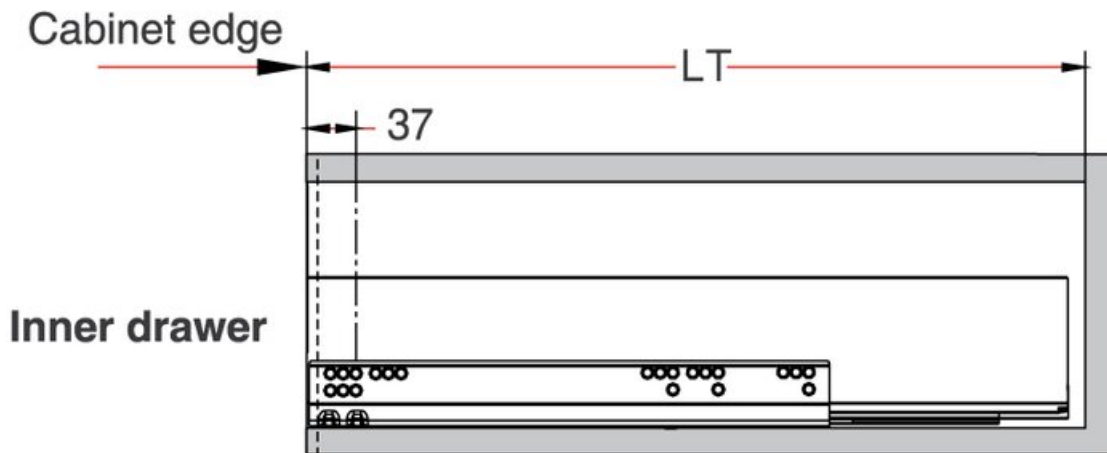

View this product online at <https://marathonhardware.com/pd/webkit-legacy77728>



## Glass front (10mm)

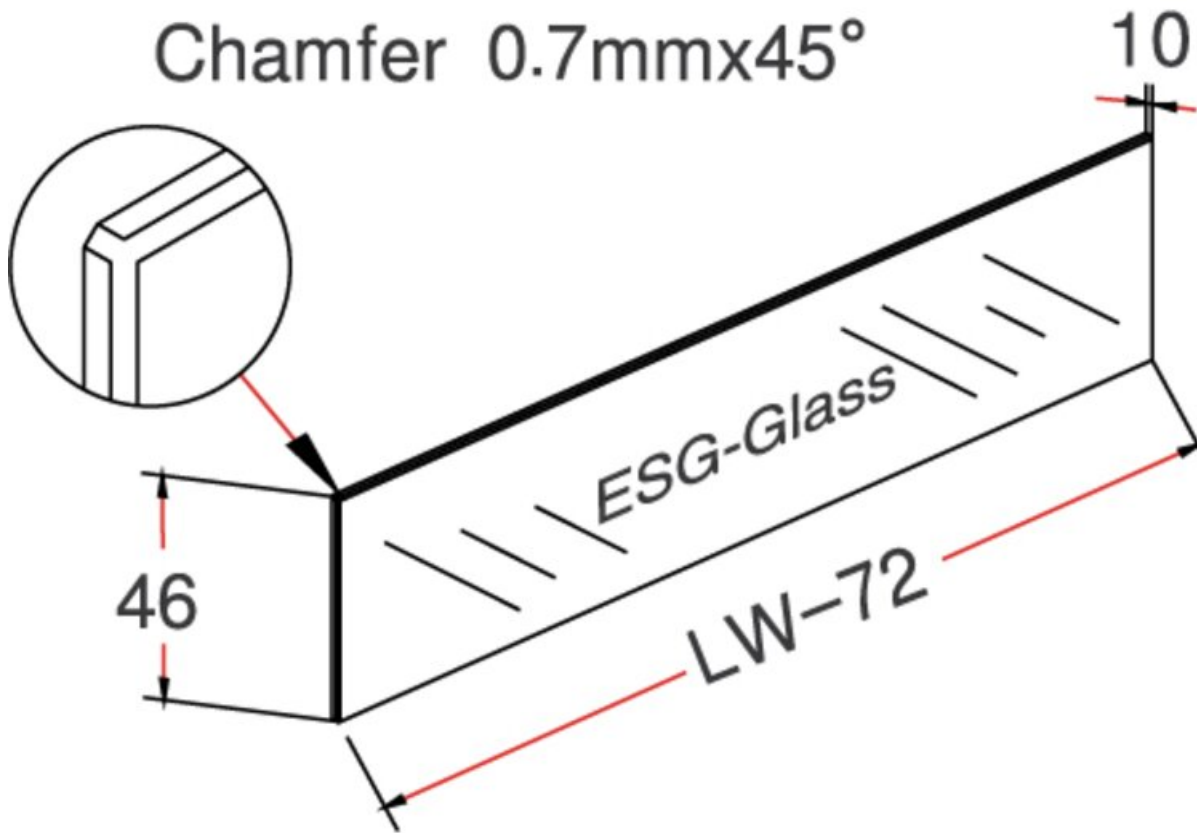

View this product online at <https://marathonhardware.com/pd/webkit-legacy77728>



## 10mm Glass-boxside

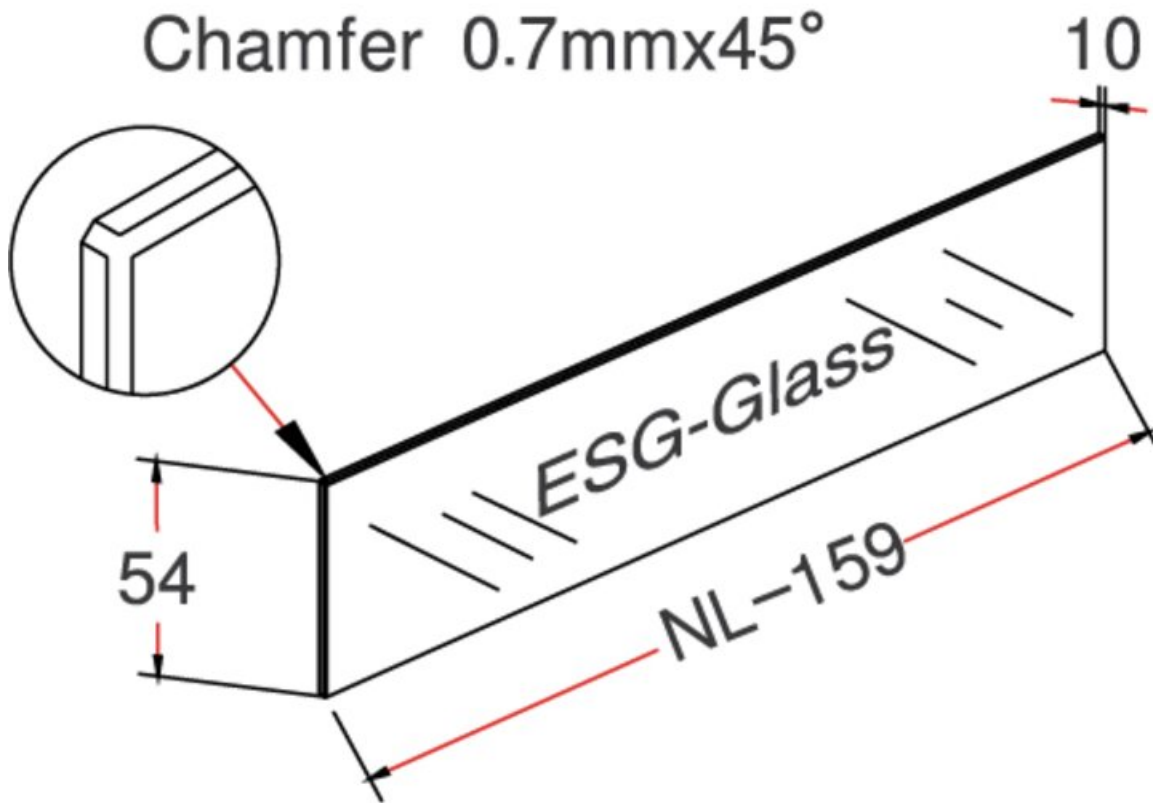

View this product online at <https://marathonhardware.com/pd/webkit-legacy77728>





## Technical Documents

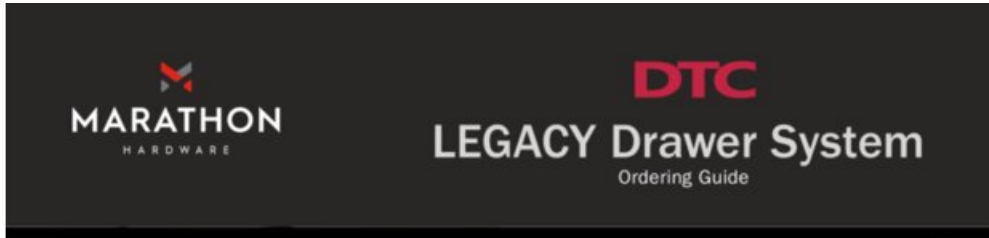

Internal Drawer With Metal Front, 88mm M Height

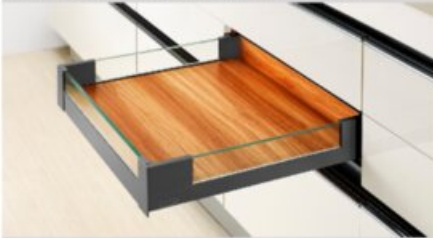

Product Features:

- Modern Straight Slim box drawer system
- Silent system guarantees smooth run without noise
- High Dynamic load capacity: 40/60kg
- Concealed slide with full extension
- Tool free assembly and removal of drawer
- 3D Adjustment

To Make this unit, order Standard Drawer plus parts listed below

### Order Glass Sides Drawer Kit with 88mm, M height sides plus these parts:

- One Pair of internal front fixing brackets for use with short height internal drawer fronts and glass
- One short height colour-matched 1100mm length metal internal drawer front which can be to cut to match your drawer width
- One pre-cut glass front according to width of your cabinet

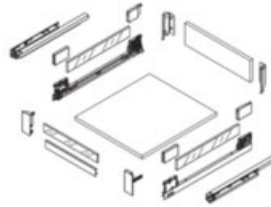

Internal Drawer Short Height Glass Fronts

Length	Part#	Qty
300mm	105-HG46-GL300	10
350mm	105-HG46-GL350	10
400mm	105-HG46-GL400	10
450mm	105-HG46-GL450	10
500mm	105-HG46-GL500	10
600mm	105-HG46-GL600	10
800mm	105-HG46-GL800	10
900mm	105-HG46-GL900	10
1000mm	105-HG46-GL1000	10
1200mm	105-HG46-GL1200	10



Internal Drawer Short Height Glass Fronts

Finish	Part#	Qty
Matte Grey	105-HT11013-GM	60
Silk White	105-HT11013-SW	60

Finish	Part#	Qty
Matte Grey	105-HT10021-GM	60
Silk White	105-HT10021-SW	60



800 840 1228 MARATHONHARDWARE.COM

View this product online at <https://marathonhardware.com/pd/webkit-legacy77728>

