



Flybox frame for door 18" anthracite

Part Number: 041-VFB45-AG



Vibo Fly Box Base Mechanism Frame Lamina 45/50cm (450/500mm or 18 in), Anthracite Grey

The Vibo FlyBox corner mechanism base is compatible with cabinet doors measuring 45/50cm (400/500mm) and 60cm (600mm). Designed to accommodate 2 tiers with a soft-close return. Reversible for versatile installation.

Finish	Anthracite Grey
Height	560 mm
Reversible	Reversible
Suggested for Cabinet (Door) Width	45/50 cm (18 in)



Technical Documents

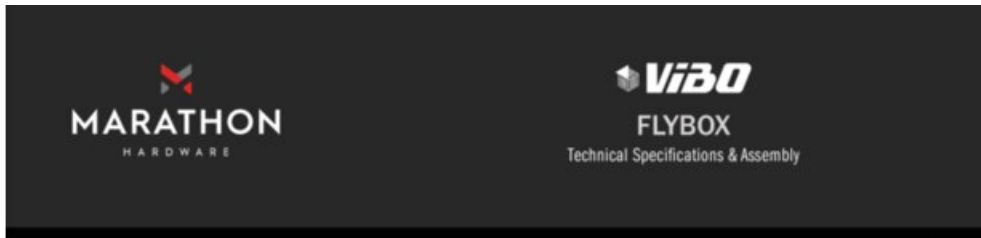

Vibo FlyBox

Product Features



The Vibo FlyBox is a modern solution for 450mm/500mm and 600mm blind corner cabinets. This easily accessible unit allows four storage boxes to be pulled out from the cabinet with minimal effort and soft-close functionality provides a whisper quiet return to the cabinet interior. Thin, yet rigid sidewalls, a high load capacity and reversible installation make the FlyBox as rugged and reliable as it is beautiful and convenient.

- Two sizes available: 450mm/500mm (18" / 19 1/4") or 600mm (24")
- Full soft-close
- Two drawers per tier
- Snap together storage boxes streamline assembly
- Reversible for left or right side installation, simplifying the ordering process
- Load capacity: 25kg (55lbs) per tier

What's In the Box

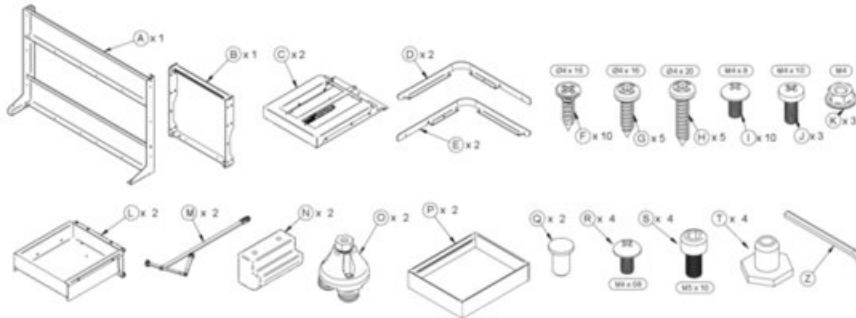

Ordering Guide

Size	Dimensions (W x D x H)	Part#
45/50cm (18"/19 1/4")	825mm x 489mm x 560mm (32 1/8" x 19 1/4" x 22 1/8")	041-VFLYBOX45-LAMINA-IS
60cm (24")	975mm x 489mm x 560mm (38 3/8" x 19 1/4" x 22 1/8")	041-VFLYBOX60-LAMINA-IS

800.840.1228 / MARATHONHARDWARE.COM

View this product online at <https://marathonhardware.com/pd/041-VFB45-AG>



Technical Documents



INTRODUCING Vibo FlyBox

The Vibo FlyBox is a modern solution for 450mm/500mm and 600mm blind corner cabinets. This easily accessible unit allows four storage boxes to be pulled out from the cabinet with minimal effort and soft-close functionality provides a whisper quiet return to the cabinet interior. Thin, yet rigid sidewalls, a high load capacity and reversible installation make the FlyBox as rugged and reliable as it is beautiful and convenient.

Product Features:

- Two sizes available: 450mm/500mm (18" / 19 1/4") or 600mm (24")
- Full soft-close
- Two drawers per tier
- Snap together storage boxes streamline assembly
- Reversible for left or right side installation, simplifying the ordering process
- Load capacity: 25kg (55lbs) per tier

View this product online at <https://marathonhardware.com/pd/041-VFB45-AG>

