

## Target J12 16mm locking pinion

**Part Number: IF21822160YA**



Locking Pinion, 16mm

The locking pinion allows for quick and easy securing to cabinet gables.

Application Type -----	16 mm
------------------------	-------

### Product Advantages

- Available in 3 sizes for different material thickness: 16mm (5/8"), 18-19mm, and 25mm (1").
- Easy pre-assembling.
- Flat pack solution for tall units.
- Suitable for furniture in kit.
- Factory pre-installed hardware eliminates the need for additional parts, ensuring quick and easy assembly on-site without loose parts.
- Mounting is extremely fast and efficient thanks to the pre-assembling of the panels.



## Technical Documents

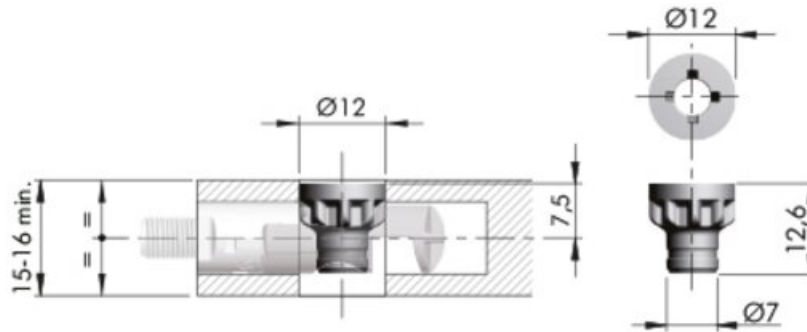

View this product online at <https://marathonhardware.com/pd/IF21822160YA>



## Technical Documents



View this product online at <https://marathonhardware.com/pd/IF21822160YA>

## Technical Documents

### TARGET J12

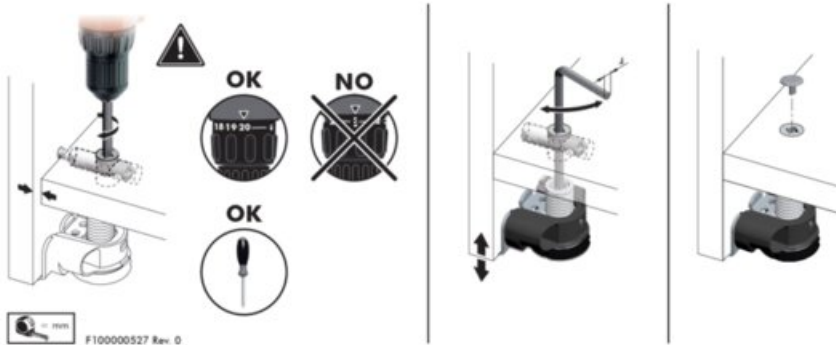
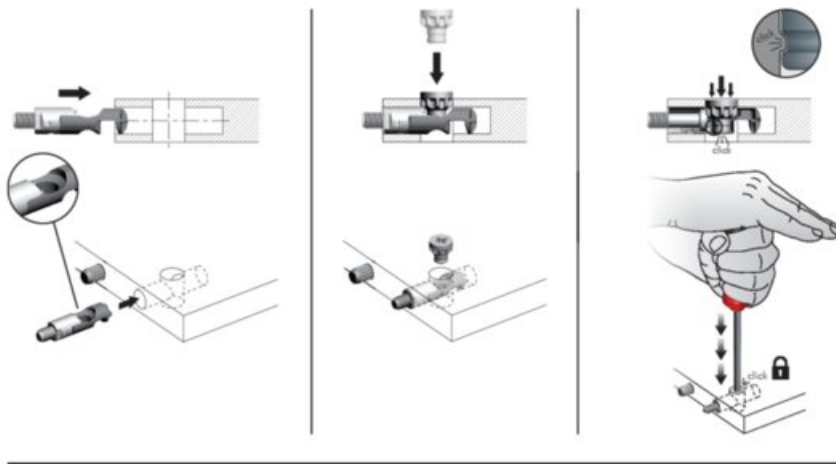
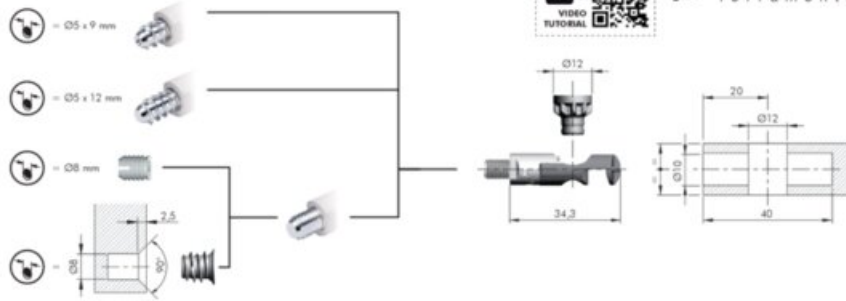

View this product online at <https://marathonhardware.com/pd/IF21822160YA>

