

# Doubewall Drawer System

## Specifications & Ordering Guide

### Standard Corner Drawer 45 Degree



### Product Features:

- Finishes: Grey, & White
- Tool free assembly and removal of drawer
- Silent system guarantees smooth running
- Full adjustment (up, down, left, right)
- Standard 83mm height sides
- Dynamic load capacity: 40kg

### Standard Drawer Kit (packaged as a complete set)

#### Standard Corner Drawer 45 Degree Kit Includes:

- One pair of Full Extension Soft-Close Slides
- One pair of Doublewall Drawer Sides (83mm Height) which includes a pair of infinity cover caps
- One pair of rear fixing brackets
- One pair of front fixing brackets

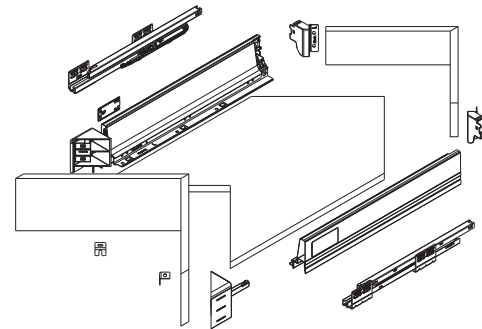

### Standard Corner Drawer Kits

Length	Grey				Qty:
600mm	105-M01600N-G	105-M010600N-W	105-M010600N-SS		20
650mm	105-M01650N-G	105-M010650N-W	105-M010650N-SS		20

# Doublewall Drawer System

## Specifications & Ordering Guide

### Space Requirements

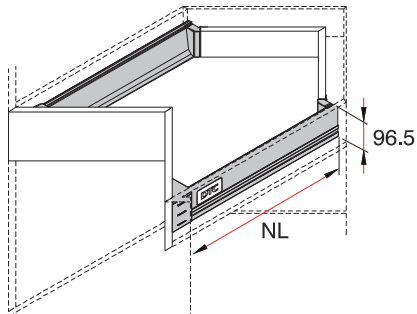

NL: Nominal length

### Installation Dimensions

NL=Nominal Slide Length  
 LT=Internal Cabinet Depth  
 LT=NL+3

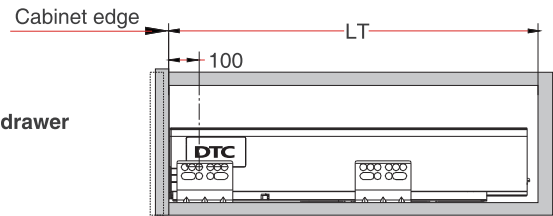

Standard drawer

### Installation Dimensions

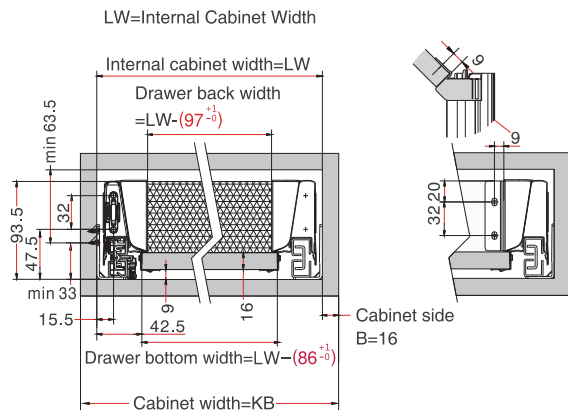

### Drilling Pattern

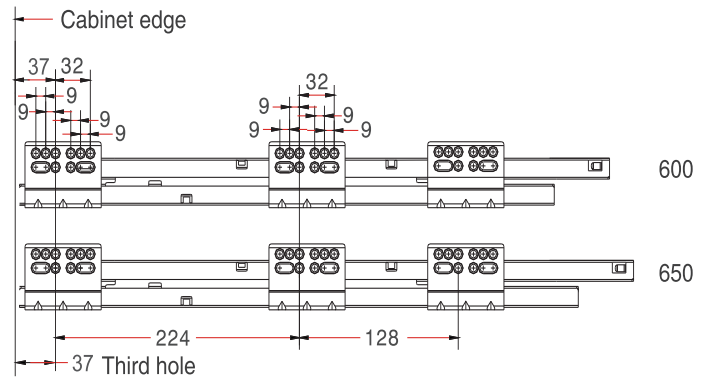

### Drawer Front, Back and Bottom Dimension

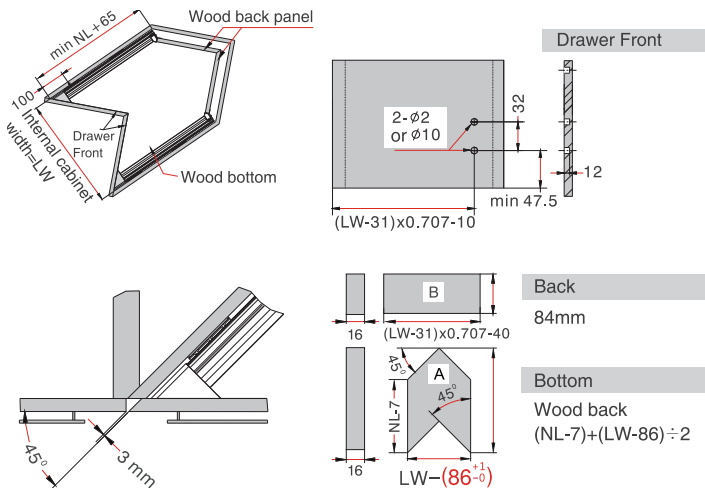

KB Cabinet width  
 LW Internal cabinet width  
 NL Nominal length

