

Front locking devices

Front locking devices - Standard mount - Side and depth adjustments

For all Progressa, Progressa+ and Progressa+ Shelf slides

- Dual steel/fiber glass-nylon construction
- Compatible with all Progressa slides
- Tool free lateral and depth adjustments
- Pre-drilling recommended \varnothing 2.5 mm (3/32")

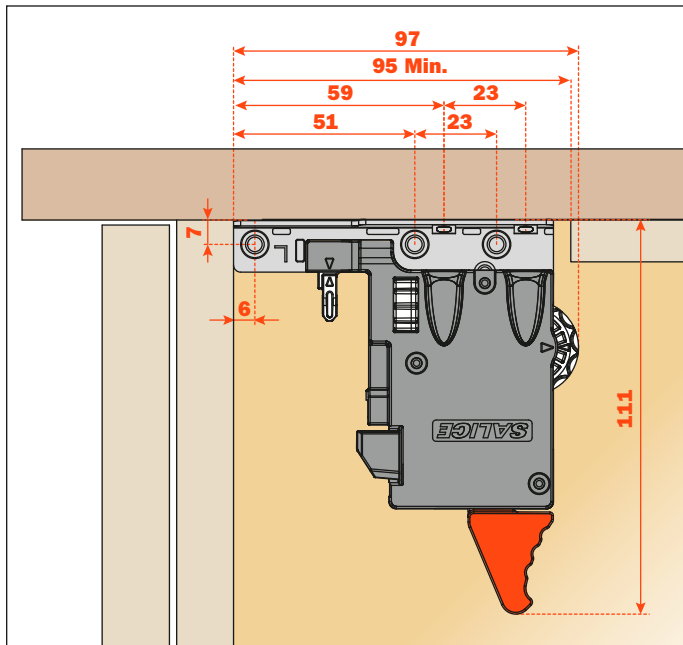

AFCGXX3B

PACKAGING
2 boxes = 100 pcs right and 100 pcs left

Assembly to the bottom

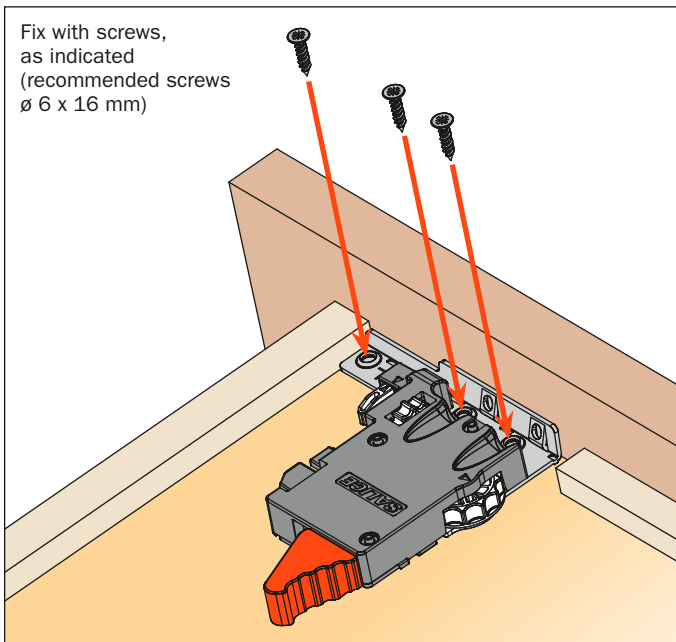

Assembly to the drawer

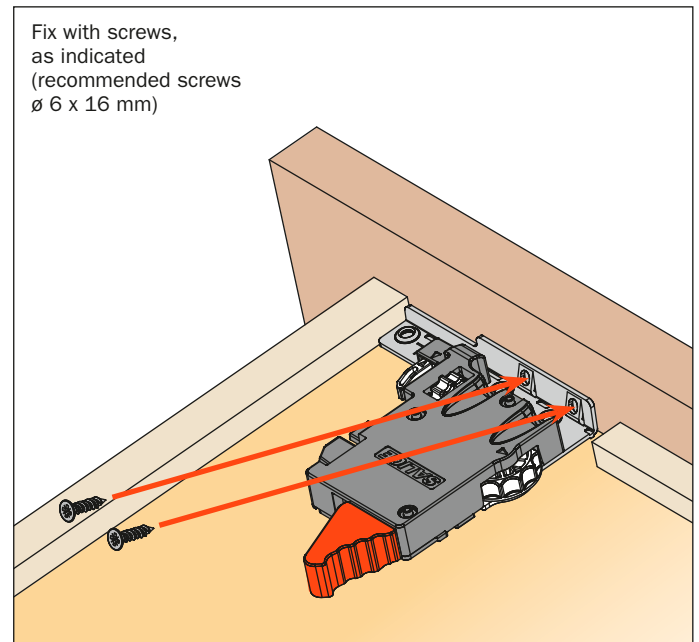

Use **drilling template ASGD704U3XA** for accurate installation of the clips, see page 51.

Front locking devices - Standard mount - Front and side fixing

For all Progressa, Progressa+ and Progressa+ Shelf slides

- Engineered thermoplastics
- Compatible with all Progressa slides
- Side fixing option
- Pre-drilling recommended \varnothing 2.5 mm (3/32")
- Minimum inside drawer width 130 mm
- Minimum inside cabinet width 172 mm

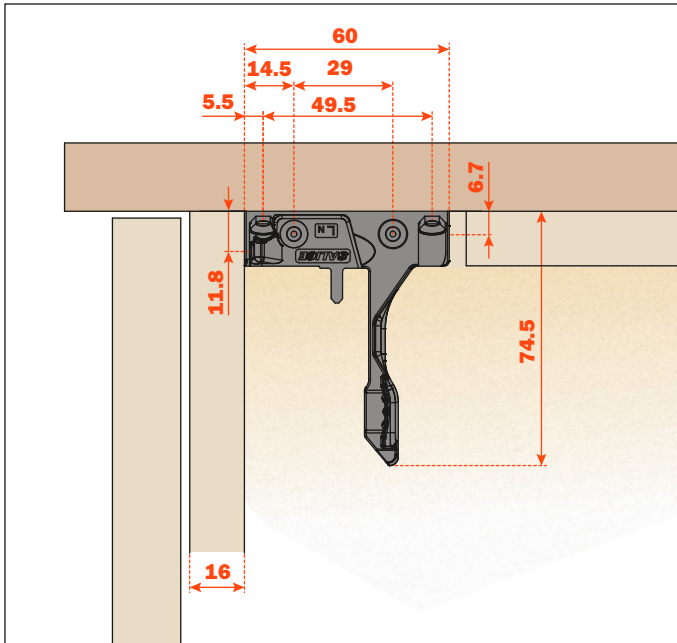

AFCEX56B

PACKAGING
2 boxes = 100 pcs right and 100 pcs left

Assembly to the bottom

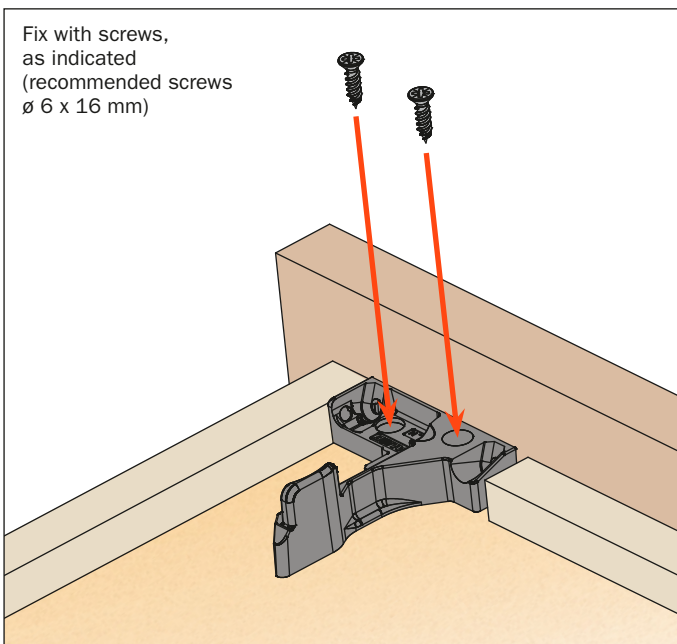

Assembly to the drawer

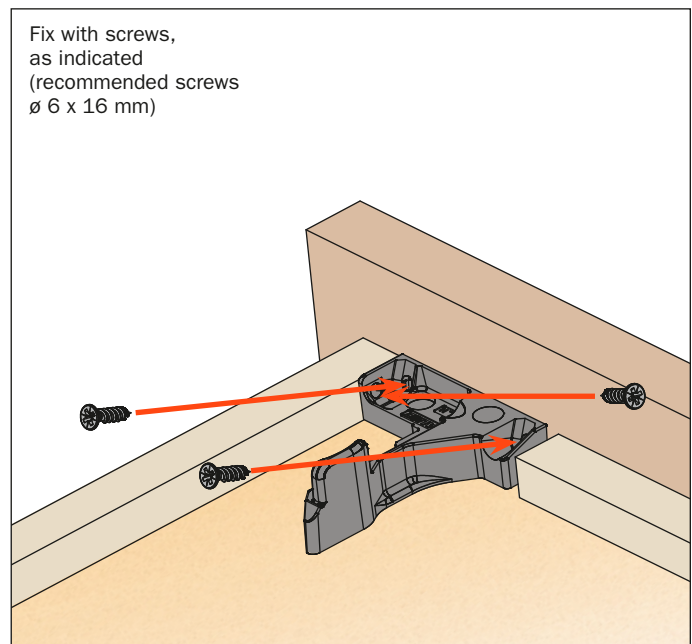

Use **drilling template ASGD504U6XA** for accurate installation of the clips, see page 53.

Drawer removal

Standard 6-way locking device - Side and depth adjustments

For all Progressa, Progressa+ and Progressa+ Shelf slides

Position hands under the front of the drawer and press on the orange levers, as indicated in the drawing, sliding the drawer out of the cabinet.

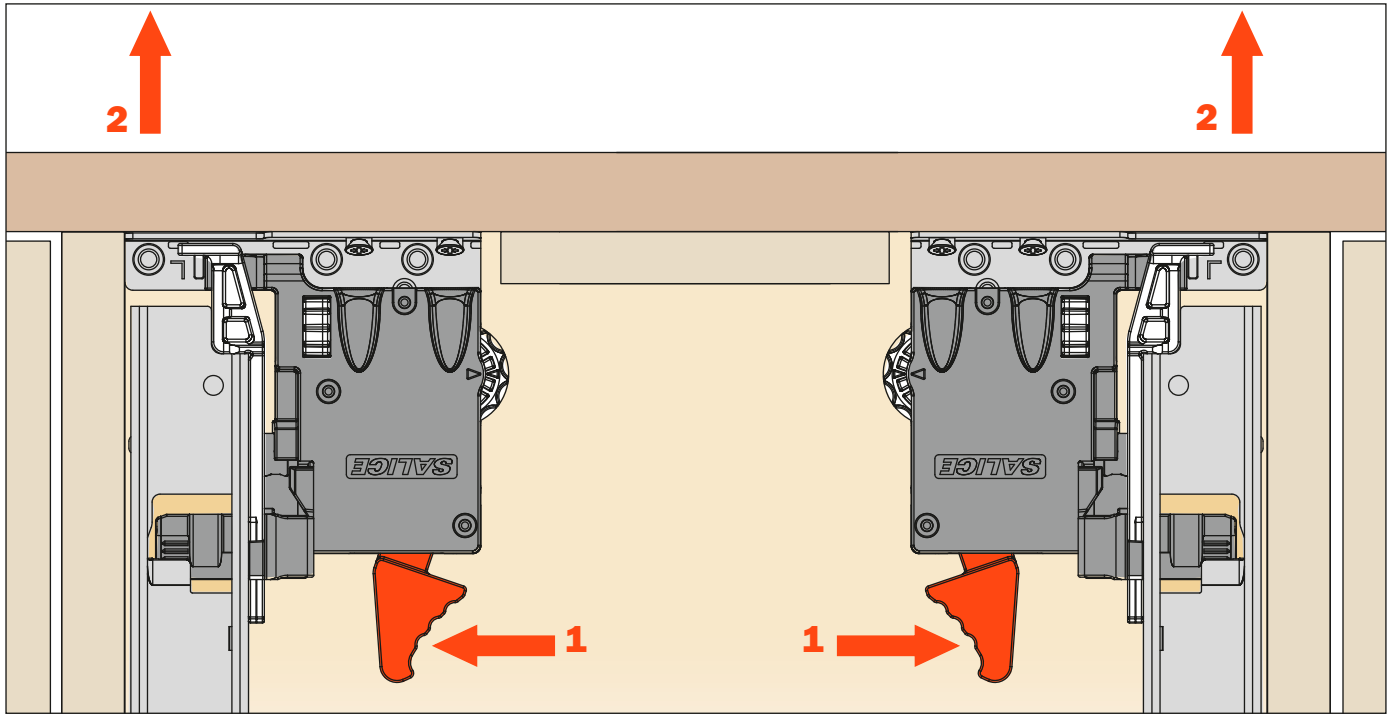

Standard 2-way locking device - Front and side fixing

For all Progressa, Progressa+ and Progressa+ Shelf slides

Position hands under the front of the drawer and press on the black levers, as indicated in the drawing, sliding the drawer out of the cabinet.

